

**For Non-Isolated
Off-Line PWM Controllers with Integrated Power MOSFET
STR5A460 Series**



Data Sheet

Description

The STR5A460 Series is power ICs for switching power supplies, incorporating a MOSFET and a current mode PWM controller IC for non-isolated Buck converter and Inverting converter topologies.

The operation mode is automatically changed, in response to load, to the fixed switching frequency, to the switching frequency control, and to the burst oscillation mode. Thus the power efficiency is improved.

The product achieves high cost-performance power supply systems with few external components.

Features

- Buck converter
- Inverting converter
- Current mode type PWM control
- Automatically changed operation mode in response to load conditions
Fixed switching frequency mode, 60 kHz (typ.)
Green mode, 23 kHz (typ.) to 60 kHz (typ.)
Burst oscillation mode
- No need for current detection resistor, building in a MOSFET used as current sense resistor
- Built-in Startup Function
,reducing power consumption, and shortening the startup time
- Built-in Error Amplifier
- Random Switching Function
- Leading Edge Blanking Function
- Soft Start Function
- Protections
Overload Protection (OLP): Auto-restart
Overvoltage Protection (OVP): Auto-restart
Thermal Shutdown with hysteresis (TSD): Auto-restart

Typical Application (Buck Converter, DIP8)

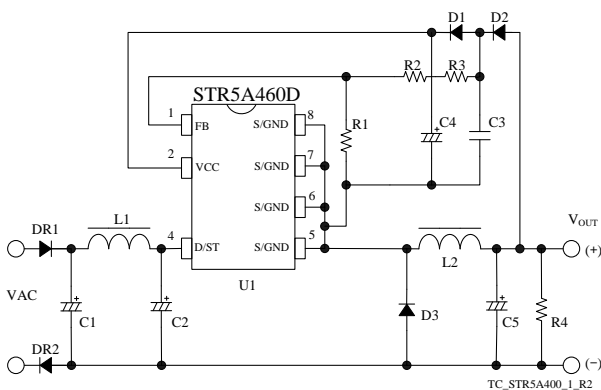

Package

DIP8

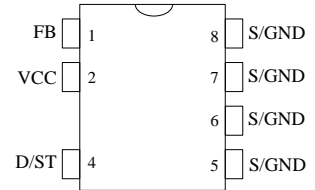

SOIC8

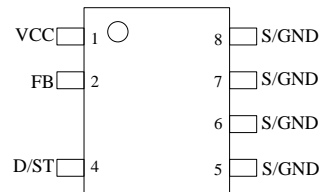

Not to scale

Selection Guide

- Electrical Characteristics
 $f_{OSC(AVG)} = 60 \text{ kHz (typ.)}$
 $V_{D/ST} = 700\text{V (max.)}$

Part Number	$R_{DS(ON)}$ (max.)	I_{DLIM} (typ.)	Package
STR5A464D	13.6 Ω	0.41 A	DIP8
STR5A464S			SOIC8

Recommended Operating Condition

	Buck Converter	Inverting Converter
Input Voltage	AC 85 V to AC 265 V	
D/ST Input Voltage	$\geq 40 \text{ V}$	
Output Voltage Range*	$> 11 \text{ V}$ $< 27.5 \text{ V}$	$> -27.5 \text{ V}$ $< -11 \text{ V}$

*Add a zener diode or a regulator to VCC pin when target output voltage is high.

Applications

- White goods
- Auxiliary power supply (lighting equipment with microcomputer, etc.)
- Power supply for motor control (actuator, etc.)
- Telecommunication equipment (convertible from 48VDC to 15VDC)
- Other Switching mode power supply, SMPS

Contents

Description	1
Contents	2
1. Absolute Maximum Ratings.....	3
2. Electrical Characteristics	3
3. Performance Curves	5
4. Block Diagram	6
5. Pin Configuration Definitions.....	6
6. Typical Application	7
7. Physical Dimensions and Marking Diagrams.....	8
7.1 DIP8.....	8
7.2 SOIC8.....	9
8. Operational Description	10
8.1 Startup Operation of IC	10
8.2 Undervoltage Lockout (UVLO)	10
8.3 Power Supply Startup and Soft Start Function	10
8.4 Constant Voltage (CV) Control.....	11
8.4.1 Buck Converter Operation	12
8.4.2 Inverting Converter Operation.....	12
8.5 Leading Edge Blanking Function	13
8.6 Random Switching Function	13
8.7 Operation Mode	13
8.8 Overload Protection (OLP).....	14
8.9 Overvoltage Protection (OVP).....	14
8.10 Thermal Shutdown (TSD)	14
9. Design Notes.....	15
9.1 External Components	15
9.1.1 Input and Output Electrolytic Capacitor.....	15
9.1.2 Inductor	15
9.1.3 VCC Pin Peripheral Circuit.....	15
9.1.4 FB Pin Peripheral Circuit	15
9.1.5 Freewheeling diode.....	16
9.1.6 Bleeder resistance	16
9.2 D/ST Pin.....	16
9.3 Inductance Calculation.....	17
9.3.1 Parameter Definition	17
9.3.2 Buck Converter.....	18
9.3.3 Inverting Converter	22
9.4 PCB Trace Layout	26
10. Pattern Layout Example	28
10.1 Buck Converter	28
10.2 Inverting Converter.....	29
11. Reference Design of Power Supply	30
11.1 Buck Converter	30
11.2 Inverting Converter.....	31
Important Notes.....	32

STR5A460 Series

1. Absolute Maximum Ratings

- The polarity value for current specifies a sink as "+," and a source as "-," referencing the IC.
- Unless otherwise specified, $T_A = 25\text{ }^\circ\text{C}$, all S/GND pins (5 pin to 8pin) are shorted.
- The pin number of SOIC8 package products is shown in bracket.

Parameter	Symbol	Test Conditions	Pins	Rating	Units	Remarks
FB Pin Voltage	V_{FB}		1 – 5 (2 – 5)	– 0.3 to 7	V	
VCC Pin Voltage	V_{CC}		2 – 5 (1 – 5)	– 0.3 to 32	V	
D/ST Pin Voltage	$V_{D/ST}$		4 – 5	– 0.3 to 700	V	
Drain Peak Current	I_{DP}	Single pulse, Within 500 ns pulse width, $V_{D/ST} \leq 400\text{ V}$	4 – 5	1.7	A	
Maximum Switching Current ⁽¹⁾	$I_{D\text{MAX}}$	Negative: Within 2 μs pulse width	4 – 5	– 0.2 to 0.97	A	5A464D
				– 0.2 to 0.91		5A464S
MOSFET Power Dissipation	P_{D1}	⁽²⁾	–	1.55	W	5A464D
				1.51		5A464S
Operating Ambient Temperature	T_{OP}		–	– 40 to 125	$^\circ\text{C}$	
Storage Temperature	T_{stg}		–	– 40 to 125	$^\circ\text{C}$	
Junction Temperature	T_j		–	150	$^\circ\text{C}$	

⁽¹⁾ Refer to MOS FET Ta-P_D curve.

⁽²⁾ When embedding this hybrid IC onto the printed circuit board (copper area in a 15mm × 15mm)

2. Electrical Characteristics

- The polarity value for current specifies a sink as "+," and a source as "-," referencing the IC.
- Unless otherwise specified, $T_A = 25\text{ }^\circ\text{C}$, all S/GND pins (5 pin to 8pin) are shorted.
- The pin number of SOIC8 package products is shown in bracket.

Parameter	Symbol	Test Conditions	Pins	Min.	Typ.	Max.	Units	Remarks
Power Supply Startup Operation								
Operation Start Voltage	$V_{CC(ON)}$		2 – 5 (1 – 5)	13.6	15.0	16.6	V	
Operation Stop Voltage	$V_{CC(OFF)}$		2 – 5 (1 – 5)	7.3	8.0	8.7	V	
Circuit Current in Operation	$I_{CC(ON)}$	$V_{CC} = 12\text{ V}$	2 – 5 (1 – 5)	–	–	2.0	mA	
Startup Circuit Operation Voltage	$V_{ST(ON)}$	$V_{CC} = 13.5\text{ V}$	4 – 5	19	29	39	V	
Startup Current	$I_{CC(ST)}$	$V_{CC} = 13.5\text{ V}$ $V_{D/ST} = 100\text{ V}$	2 – 5 (1 – 5)	– 2.7	– 1.5	– 0.5	mA	
PWM Operation								
Average PWM Switching Frequency	$f_{OSC(AVG)}$	$V_{FB} = 2.44\text{ V}$	4 – 5	53	60	67	kHz	
Switching Frequency Modulation Deviation	Δf		4 – 5	–	2.8	–	kHz	

STR5A460 Series

Parameter	Symbol	Test Conditions	Pins	Min.	Typ.	Max.	Units	Remarks
Feedback Reference Voltage	$V_{FB(REF)}$		1-5 (2-5)	2.44	2.50	2.56	V	
Feedback Current ⁽¹⁾	$I_{FB(OP)}$	$V_{FB} = 2.3 \text{ V}$	1-5 (2-5)	-2.4	-0.8	-	μA	
Minimum Sampling Time	t_{FBMS}		1-5 (2-5)	-	-	2.5	μs	
Standby Drain Current	I_{DSTB}		4-5	-	50	-	mA	
Standby Operation Cycle	t_{STBOP}		4-5	530	740	940	μs	
Maximum ON Duty	D_{MAX}		4-5	50	57	64	%	
Protection								
Leading Edge Blanking Time ⁽¹⁾	t_{BW}		-	-	230	-	ns	
Drain Current Limit	I_{DLIM}		4-5	0.37	0.41	0.45	A	
OVP Threshold Voltage	$V_{CC(OVP)}$		2-5 (1-5)	27.5	29.3	31.3	V	
OLP Delay Time at Startup	t_{OLP}	$V_{FB} = 0 \text{ V}$	4-5	-	72	-	ms	
Standby Blanking Time at Startup	$t_{STB(INH)}$	$V_{FB} = 2.6 \text{ V}$	4-5	3.5	5.2	6.8	ms	
Thermal Shutdown Operating Temperature ⁽¹⁾	$T_{j(TSD)}$		-	135	-	-	$^{\circ}\text{C}$	
Thermal Shutdown Hysteresis ⁽¹⁾	$T_{j(TSDHYS)}$		-	-	70	-	$^{\circ}\text{C}$	
Power MOSFET								
Drain Leakage Current ⁽¹⁾	I_{DSS}	$T_j = 125 \text{ }^{\circ}\text{C}$ $V_{D/ST} = 584 \text{ V}$	4-5	-	-	50	μA	
On Resistance	$R_{DS(ON)}$	$I_D = 41 \text{ mA}$	4-5	-	11.0	13.6	Ω	
Switching Time	t_f		4-5	-	-	250	ns	
Thermal Characteristics								
Thermal Resistance Junction to Case ⁽¹⁾⁽²⁾	θ_{j-C}		-	-	-	15	$^{\circ}\text{C/W}$	5A464D
				-	-	16		5A464S

⁽¹⁾ Design assurance

⁽²⁾ Case temperature (T_C) measured at the center of the case top surface

STR5A460 Series

3. Performance Curves

• STR5A464D

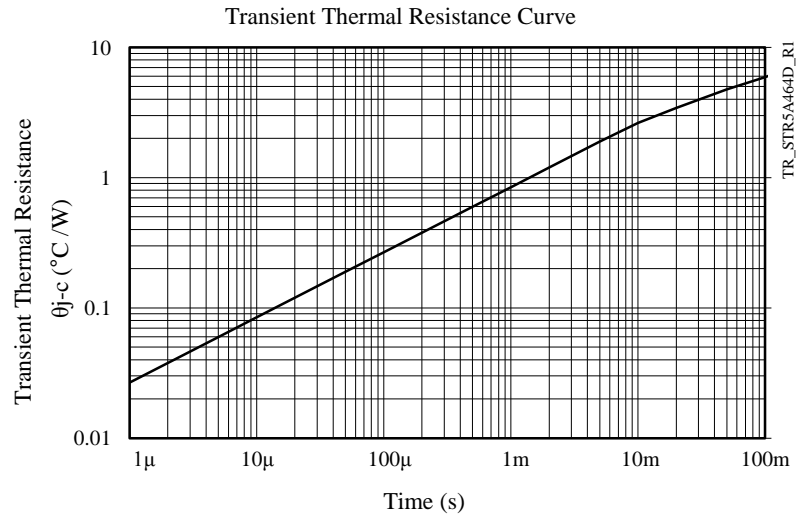
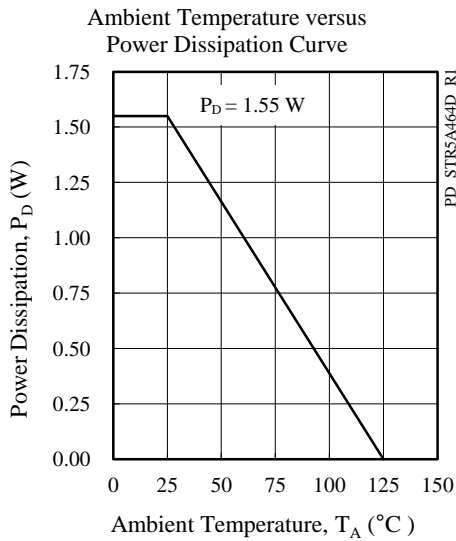

• STR5A464S

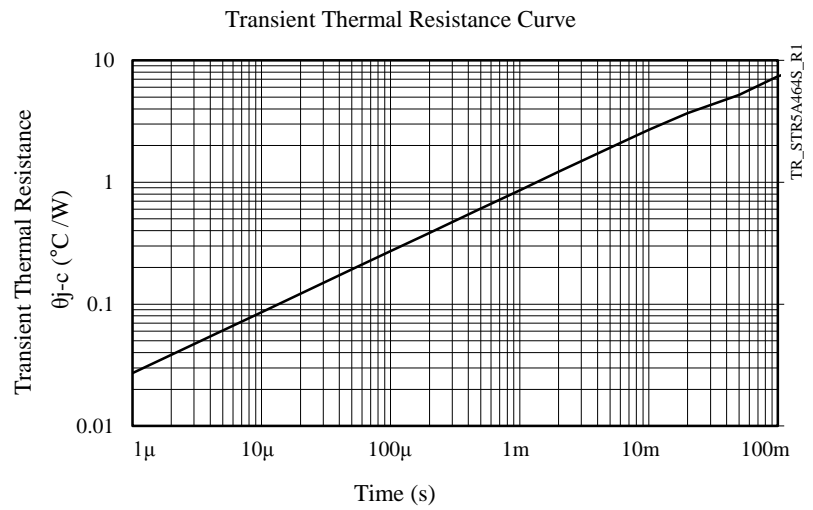
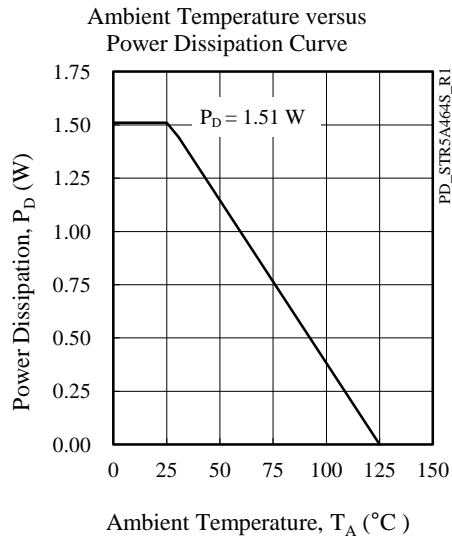

STR5A460 Series

4. Block Diagram

The pin number of SOIC8 package products is shown in bracket.

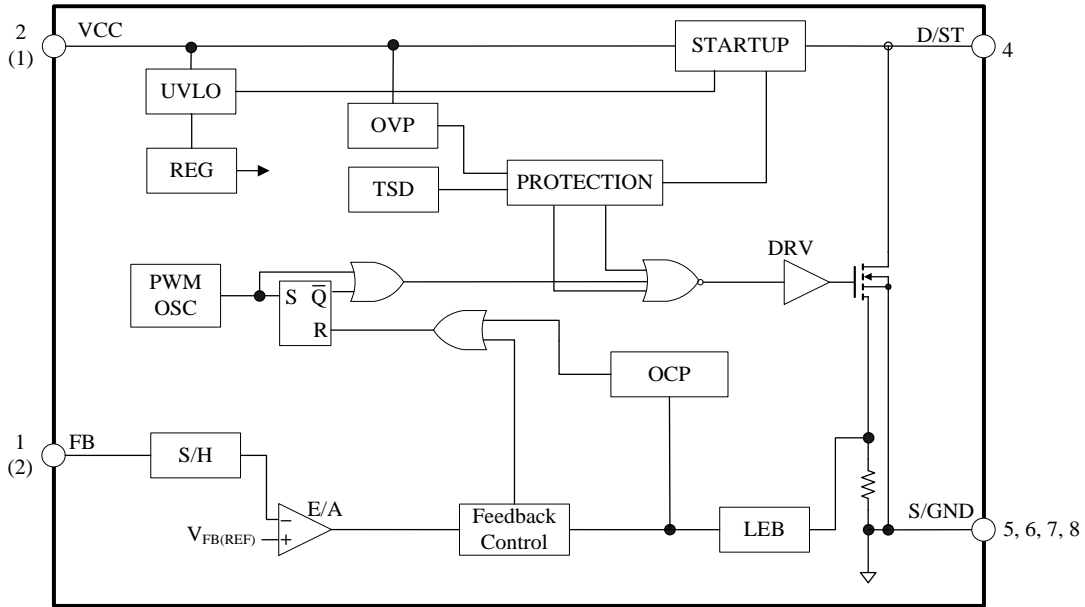

BD_STR5A400_R2

5. Pin Configuration Definitions

- DIP8

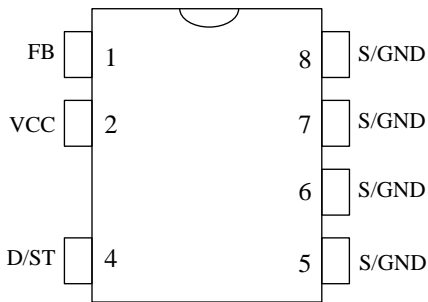

Pin	Name	Descriptions
1	FB	Constant voltage control signal input
2	VCC	Power supply voltage input for control part and Overvoltage Protection (OVP) signal input
3	–	(Pin removed)
4	D/ST	MOSFET drain and startup current input
5~8	S/GND	MOSFET source and ground

- SOIC8

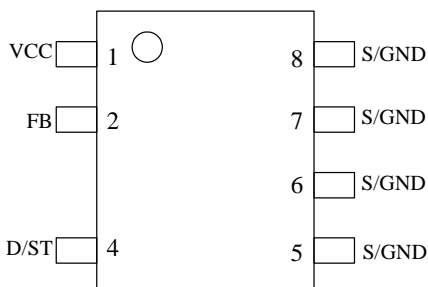

Pin	Name	Descriptions
1	VCC	Power supply voltage input for control part and Overvoltage Protection (OVP) signal input
2	FB	Constant voltage control signal input
3	–	(Pin removed)
4	D/ST	MOSFET drain and startup current input
5~8	S/GND	MOSFET source and ground

6. Typical Application

Figure 6-1 and Figure 6-2 are the example circuits of DIP8 products.

To enhance the heat dissipation, the wide pattern layout of the S/GND pin (5 through 8 pin) is recommended.

When the absolute value of the output voltage $|V_{OUT}|$ is 27.5 V or more, add a zener diode DZ1 connected to D1 in serial as shown in Figure 6-3. Using the maximum on-duty of 50 % in the steady state operation, the condition of $|V_{OUT}|$ is shown below:

$$|V_{OUT}| : 11V < |V_{OUT}| - V_{DZ1} < 27.5V$$

$$|V_{OUT}| \text{ in response to the input voltage : For Buck topology, } |V_{OUT}| \leq \frac{1}{2} \times \text{Input voltage}$$

$$\text{For Inverting topology, } |V_{OUT}| \leq \text{Input voltage}$$

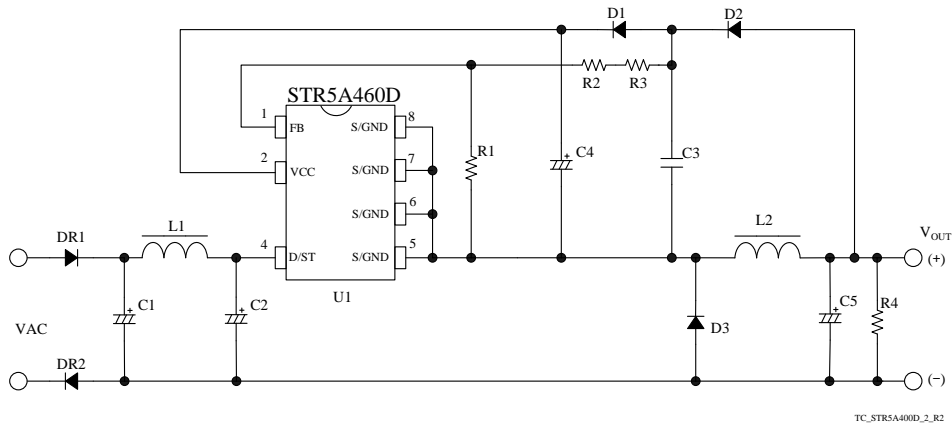

Figure 6-1. Buck Converter

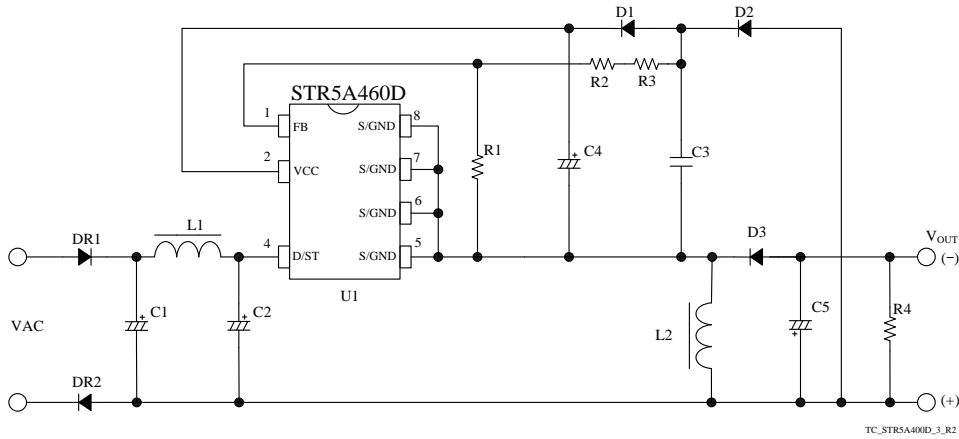

Figure 6-2. Inverting Converter

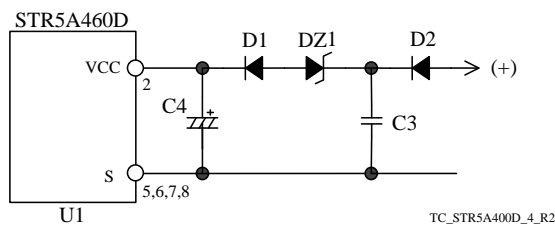
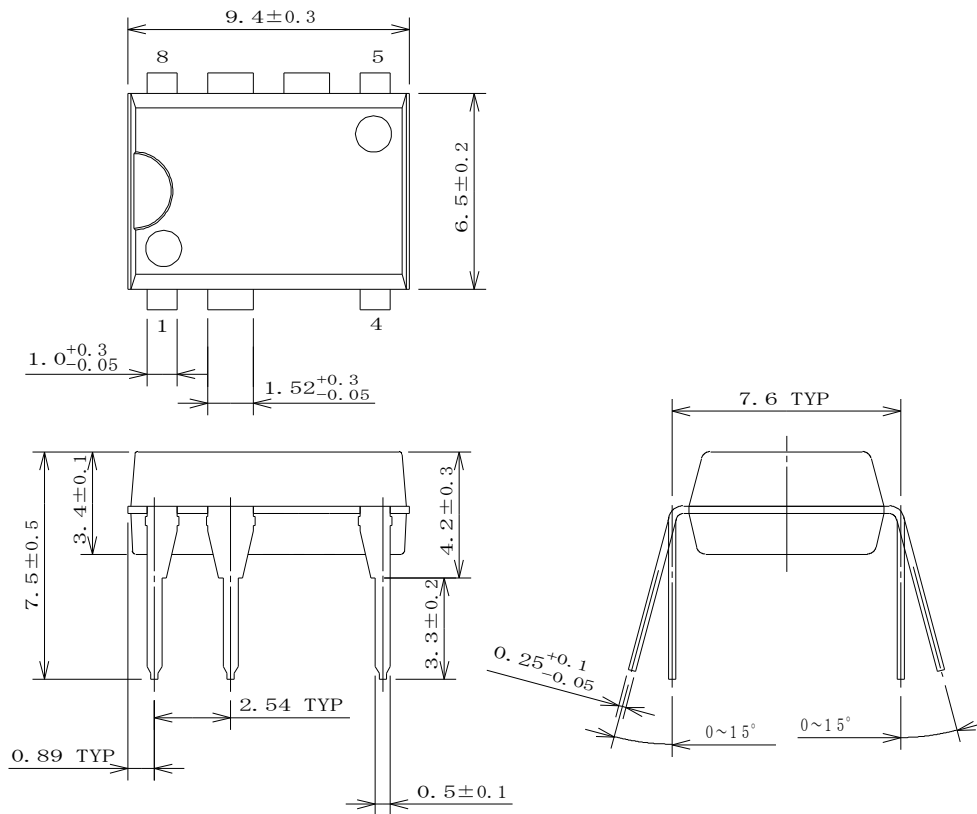

Figure 6-3. Increasing the absolute value of $|V_{OUT}|$

7. Physical Dimensions and Marking Diagrams

7.1 DIP8

• Physical Dimensions



NOTES:

- 1) Units: mm
- 2) Pb-free. Device composition compliant with the RoHS directive

• Marking Diagram

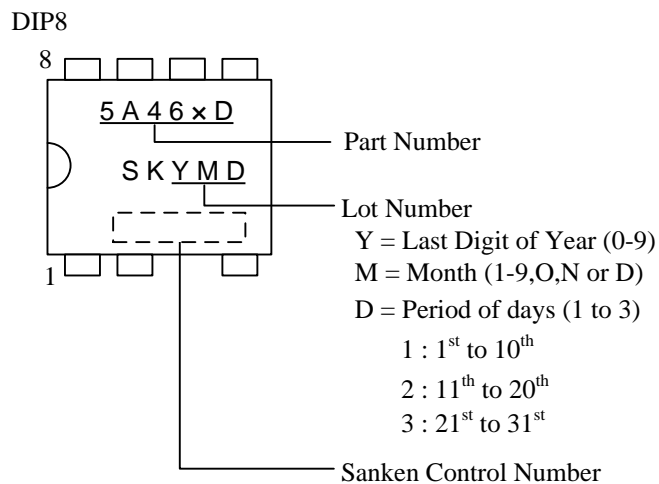

STR5A460 Series

7.2 SOIC8

- Physical Dimensions

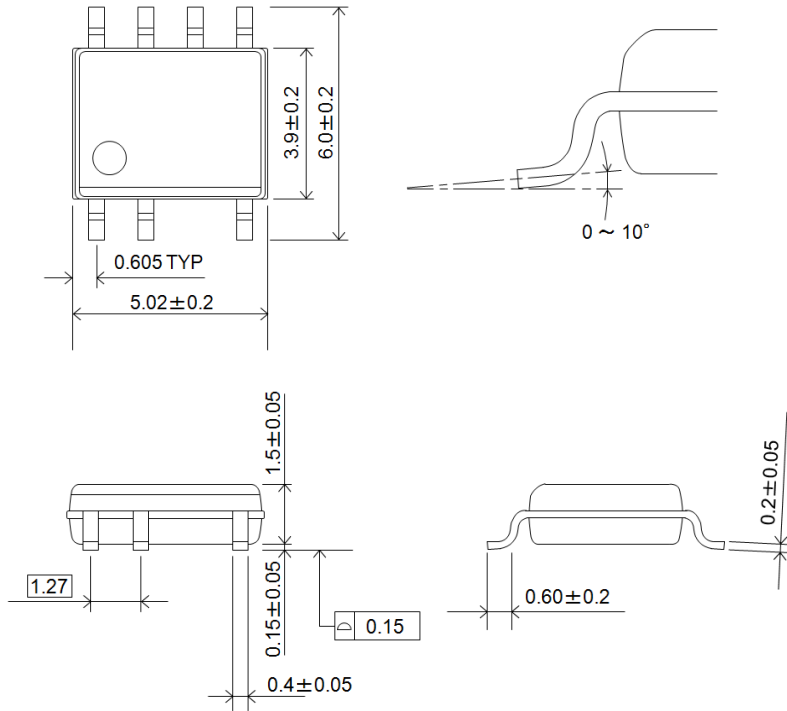

Land Pattern Example (not to scale)

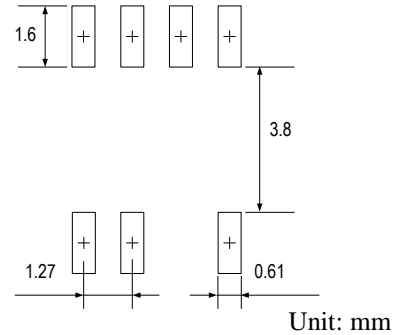

NOTES:

- Units: mm
- Pb-free. Device composition compliant with the RoHS directive

- Marking Diagram

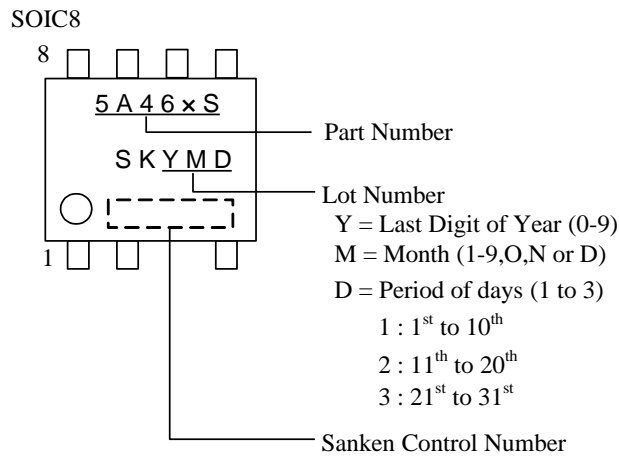

8. Operational Description

All of the parameter values used in these descriptions are typical values, unless they are specified as minimum or maximum. With regard to current direction, "+" indicates sink current (toward the IC) and "-" indicates source current (from the IC).

In Section 8, the pin number of SOIC8 package products is shown in bracket.

The common items of Buck converter and Inverting are described by using Buck converter.

8.1 Startup Operation of IC

Figure 8-1 shows the circuit around VCC pin.

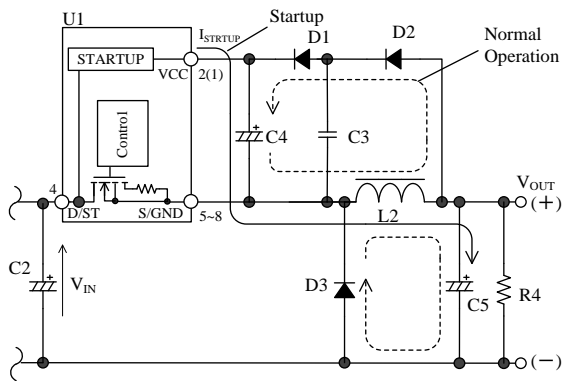

Figure 8-1. VCC Pin Peripheral Circuit in Buck Converter

The IC incorporates the startup circuit. The circuit is connected to D/ST pin. When D/ST pin voltage reaches the Startup Circuit Operation Voltage $V_{ST(ON)} = 29\text{ V}$, the startup circuit starts operation.

During the startup process, the constant current, $I_{CC(ST)} = -1.5\text{ mA}$, charges C4 at VCC pin. When VCC pin voltage increases to $V_{CC(ON)} = 15.0\text{ V}$, the control circuit starts switching operation.

After switching operation begins, the startup circuit turns off automatically so that its current consumption becomes zero.

The approximate startup time t_{START} is calculated as follows:

$$t_{START} = C4 \times \frac{V_{CC(ON)} - V_{CC(INT)}}{|I_{CC(ST)}|} \text{ (s)} \quad (1)$$

where,

t_{START} is the startup time of IC (s),

$V_{CC(INT)}$ is the initial voltage on VCC pin (V).

When the internal power MOSFET turns off, the output voltage, V_{OUT} , charges C4 through D1 and D2

(Refer to Figure 8-1).

The voltage between VCC pin and S/GND pin in the steady state operation is calculated as follows, where V_{FD1} , V_{FD2} and V_{FD3} are the forward voltage of D1, D2 and D3 respectively:

$$V_{CC} = V_{OUT} + V_{FD3} - (V_{FD1} + V_{FD2}) \text{ (V)} \quad (2)$$

8.2 Undervoltage Lockout (UVLO)

Figure 8-2 shows the relationship of VCC pin voltage and the circuit current, I_{CC} . When VCC pin voltage increases to $V_{CC(ON)} = 15.0\text{ V}$, the control circuit starts switching operation and the circuit current, I_{CC} , increases. When VCC pin voltage decreases to $V_{CC(OFF)} = 8.0\text{ V}$, the control circuit stops its operation by the Undervoltage Lockout (UVLO) circuit, and reverts to the state before startup.

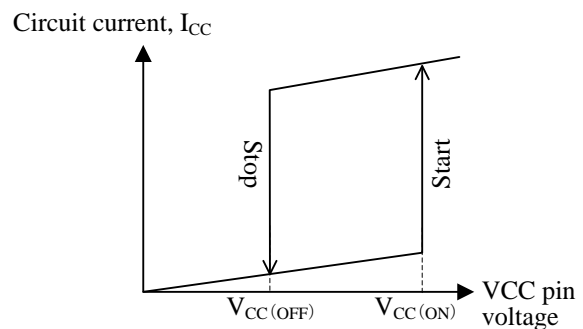

Figure 8-2. Relationship between VCC Pin Voltage and I_{CC}

8.3 Power Supply Startup and Soft Start Function

The Soft Start Function reduces the voltage and the current stress of the internal power MOSFET and the freewheeling diode, D3.

Figure 8-3 shows the startup waveforms. After the IC starts, during the Standby Blanking Time at Startup, $t_{STB(INH)}$, the burst oscillation mode is disabled to operate the soft start.

The IC activates the soft start circuitry during the startup period. The soft start time is fixed to about 5.2 ms. During the soft start period, the overcurrent threshold is increased step-wisely (7 steps). The IC operates switching operation by the frequency responding to FB pin voltage until the output reaches the setting voltage.

Here, the t_{LIM} is defined as the period until FB pin voltage reaches 1.6 V after the IC starts. When the t_{LIM} reaches the OLP Delay Time at Startup, t_{OLP} , of 72 ms

and more, the IC stops switching operation. Thus, it is necessary to adjust the value of output electrolytic capacitor, C5 so that the t_{LIM} is less than t_{OLP} .

If VCC pin voltage reaches $V_{CC(OFF)}$ and a startup failure occurs as shown in Figure 8-4, increase C4 value or decrease C5 value. Since the larger capacitance causes the longer startup time of IC, it is necessary to check and adjust the startup process based on actual operation in the application.

Since the Leading Edge Blanking Function (Refer to Section 8.5) is disabled during the soft start period, the on-time may be less than the Leading Edge Blanking Time ($t_{BW} = 230$ ns).

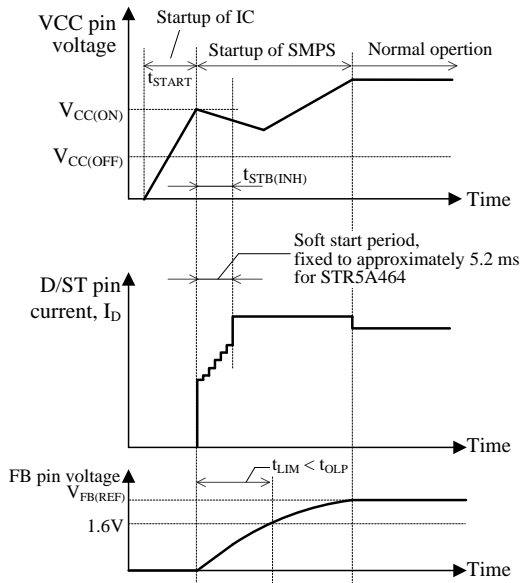

Figure 8-3. Startup Waveforms

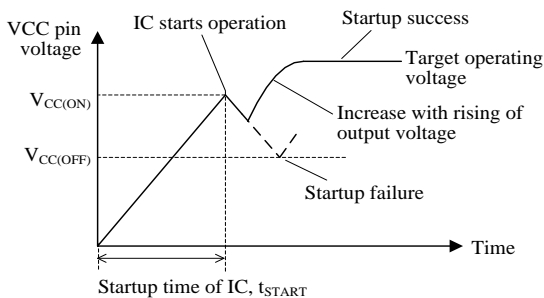

Figure 8-4. VCC Pin Voltage during Startup Period

8.4 Constant Voltage (CV) Control

The constant voltage (CV) control for power supply output adopts the peak-current-mode control method which enhances the response speed and the stable operation.

The target voltage, V_{SC} , is made from the voltage value sampled FB pin voltage on pulse by pulse basis at the point of $t_{FBFS} = 2.5 \mu s$ (max.) after turning off the internal power MOSFET. The V_{ROCP} is the voltage value of the built-in drain current sense resistor. The IC controls so that the peak voltage of V_{ROCP} is close to V_{SC} by comparing them at the internal FB comparator (Refer to Figure 8-5 and Figure 8-6).

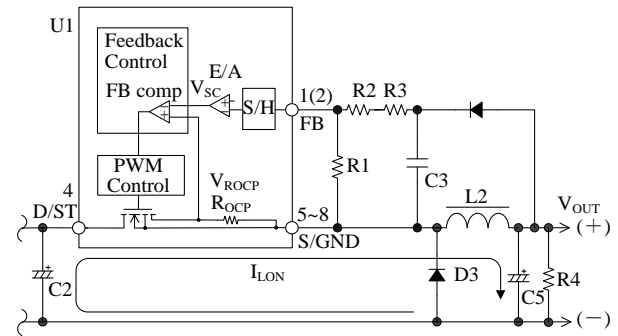

Figure 8-5. FB Pin Peripheral Circuit in Buck Converter

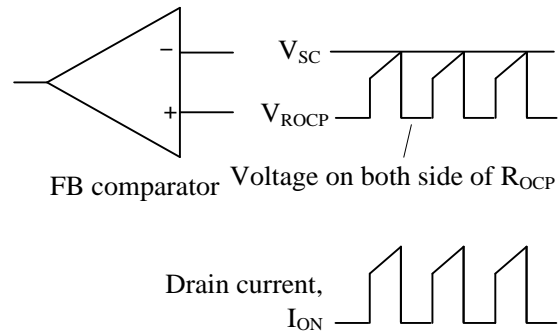

Figure 8-6. Drain Current I_D and FB Comparator in Steady State Operation

- **Decreasing Load**
When the output load decreases, the FB pin voltage increases in response to the increase of the output voltage. Since V_{SC} which is the output voltage of internal error amplifier becomes low, the peak value of V_{ROCP} is controlled to become low, and the peak of the drain current decreases. This control prevents the output voltage from increasing.
- **Increasing Load**
When the output load increases, the control circuit operates the reverse of the former operations. Since V_{SC} becomes high, the peak drain current increases. This control prevents the output voltage from decreasing.

8.4.1 Buck Converter Operation

Figure 8-7 shows the output current path in the Buck converter. Figure 8-8 shows the operational waveforms.

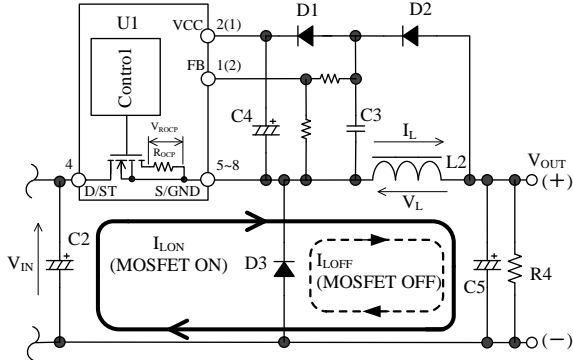

Figure 8-7. Output Current Path in Buck Converter

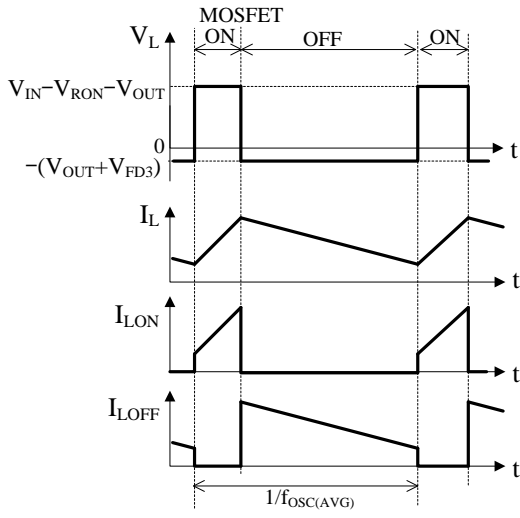

Figure 8-8. Operational Waveforms in Buck Converter

In the Buck converter, the PWM control is described in the following.

1) PWM On-Time Period

When the internal power MOSFET turns on, the I_{LON} current flows as shown in Figure 8-7, and the inductor, L2, stores some energy. Since the I_{LON} flows through the internal sense resistor, R_{OCP} , the voltage of R_{OCP} is detected as the current detection voltage, V_{ROCP} . FB pin voltage is the voltage divided C3 voltage by voltage dividing resistors, and the target voltage, V_{SC} , is given by FB pin voltage. When V_{ROCP} reaches V_{SC} , the power MOSFET turns off.

2) PWM Off-Time Period

When the internal power MOSFET turns off, the back electromotive force occurs in the inductor, L2, the freewheeling diode, D3, is forward biased and turns on. Thus, the I_{LOFF} current flows as shown in Figure 8-7.

As shown in Figure 8-8, after the average switching period, $1/f_{OSC(AVG)}$, the power MOSFET turns on again, and the event moves to the previous 1).

The output current is equal to the average inductor current of L2.

8.4.2 Inverting Converter Operation

Figure 8-9 shows the output current path in the Inverting converter. Figure 8-10 shows the operational waveforms.

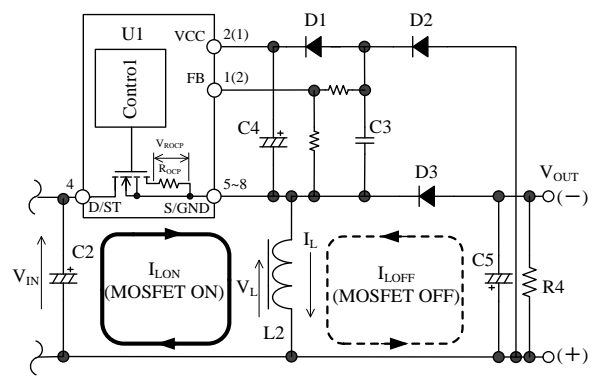

Figure 8-9. Output Current Path in Inverting Converter

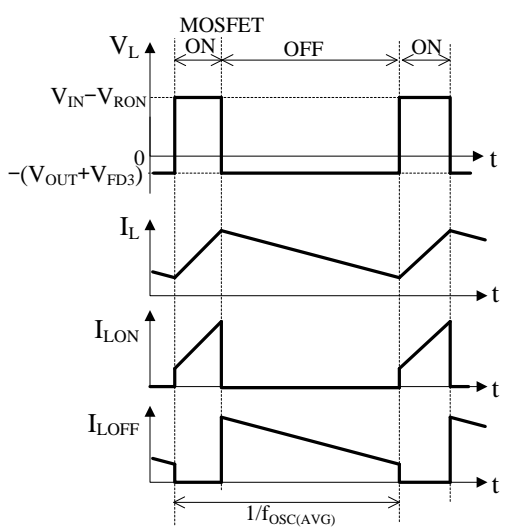

Figure 8-10. Operational Waveforms in Inverting Converter

In the Inverting converter, the PWM control is described in the following.

- 1) PWM On-Time Period
When the internal power MOSFET turns on, the I_{LON} current flows as shown in Figure 8-9, and the inductor, L2, stores some energy. Since the I_{LON} flows through the internal sense resistor, R_{OCP} , the voltage of R_{OCP} is detected as the current detection voltage, V_{ROCP} . FB pin voltage is the voltage divided C3 voltage by voltage dividing resistors, and the target voltage, V_{SC} , is given by FB pin voltage. When V_{ROCP} reaches V_{SC} , the power MOSFET turns off.
- 2) PWM Off-Time Period
When the internal power MOSFET turns off, the back electromotive force occurs in the inductor, L2, the freewheeling diode, D3, is forward biased and turns on. Thus, the I_{LOFF} current flows as shown in Figure 8-9. As shown in Figure 8-10, after the average switching period, $1/f_{OSC(AVG)}$, the power MOSFET turns on again, and the event moves to the previous 1).

The output current is equal to the average current of I_{LOFF} of L2.

8.5 Leading Edge Blanking Function

The constant voltage control for power supply output adopts the peak-current-mode control method. The peak drain current is detected by the internal sense resistor, R_{OCP} . Just in turning on the internal power MOSFET, the steep surge current would occur.

If the Overcurrent Protection (OCP) responds to the voltage caused by that surge current, the power MOSFET may be turned off.

To prevent that response, the OCP detection is disabled during Leading Edge Blanking ($t_{BW} = 230$ ns) just after the power MOSFET turns on.

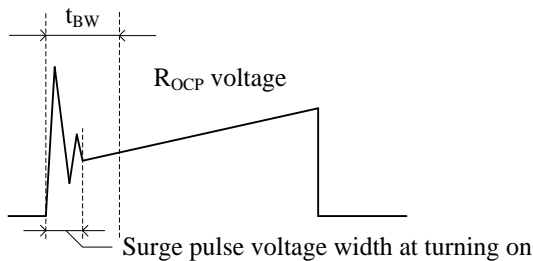

Figure 8-11. Leading Edge Blanking

8.6 Random Switching Function

The switching frequency is randomly modulated by superposing the modulating frequency on $f_{OSC(AVG)}$. This

function reduces the conduction noise compared with other products without this function, and simplifies noise filtering of the input lines of power supply.

8.7 Operation Mode

As shown in Figure 8-12, when the output power is decreasing, together with the decrease of the drain current I_D of the internal power MOSFET, the operation mode is automatically changed to the fixed switching frequency mode (60 kHz), to the Green mode controlled the switching frequency (23 kHz to 60 kHz), and to the burst oscillation mode controlled by an internal oscillator. In the Green mode, the number of switching is reduced. In the burst oscillation mode, the switching operation is stopped during a constant period. Thus, the switching loss is reduced, and the power efficiency is improved.

When the output power becomes light and the drain current decreases to the Standby Drain Current, I_{DSTB} , the burst oscillation mode is getting started. Figure 8-13 shows the drain current waveforms of point A and B in Figure 8-12. The burst period of burst oscillation mode is the Standby Operation Cycle, $t_{STBOP} = 740$ μ s. In the burst period, the number of minimum switching times is reduced up to one.

Since the oscillator for setting burst oscillation cycle and the oscillator for setting the switching oscillation frequency are not synchronized each other, the first switching frequency in the burst period may be raised.

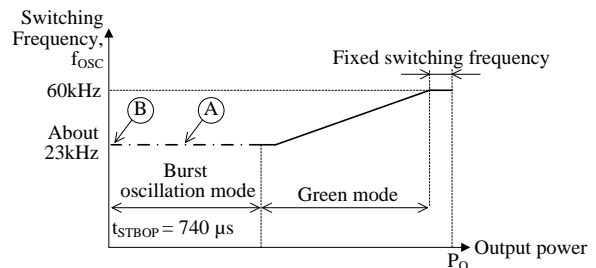

Figure 8-12. Switching Frequency in Response to Output Power

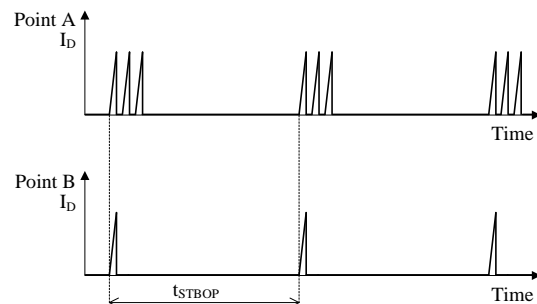

Figure 8-13. Switching Waveform at Burst Oscillation Mode

8.8 Overload Protection (OLP)

When the drain current, I_D , reaches the Drain Current Limit, I_{DLIM} , the internal power MOSFET turns off. Figure 8-14 shows the characteristic of output voltage and current.

The output voltage decreases in the overload state, and FB pin voltage also decreases. When the period keeping FB pin voltage less than 1.6 V continues during the OLP Delay Time at Startup ($t_{OLP} = 72$ ms), the Overload Protection (OLP) is activated, and the IC stops switching operation. Thus, VCC pin voltage decreases to $V_{CC(OFF)}$, and the control circuit stops operation. After that, the startup circuit is activated, VCC pin voltage increases to $V_{CC(ON)}$ by the startup current, and the control circuit operates again. Thus, the intermittent operation by UVLO is repeated in the OLP state (Refer to Figure 8-15). This intermittent operation reduces the stress of parts including the power MOSFET and the freewheeling diode. In addition, this operation reduces power consumption because the switching period in this intermittent operation is much shorter than the oscillation stop period. When the abnormal condition is removed, the IC returns to normal operation automatically.

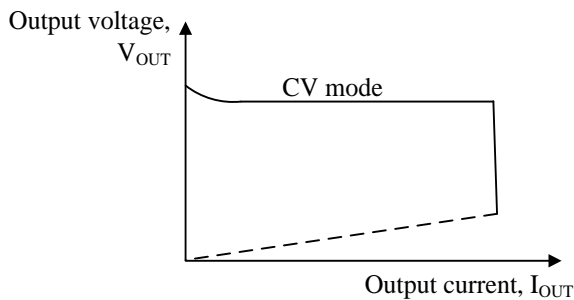

Figure 8-14. Overload Characteristics

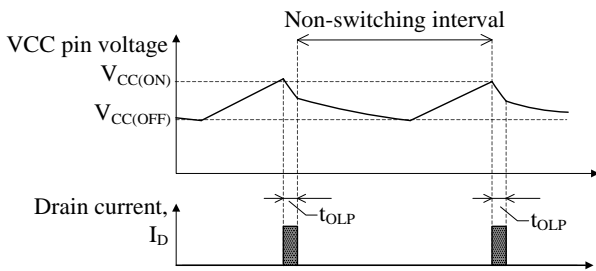

Figure 8-15. OLP Operational Waveform

8.9 Overvoltage Protection (OVP)

When the voltage between VCC pin and S/GND pin increases to $V_{CC(OVP)} = 29.3$ V or more, the Overvoltage Protection (OVP) is activated and the IC stops switching operation. The intermittent operation by UVLO is

repeated in the OVP state. Refer to Section 8.8 about the intermittent operation by UVLO.

When the abnormal condition is removed, the IC returns to normal operation automatically.

The approximate value of output voltage $V_{OUT(OVP)}$ in the OVP condition is calculated by using Equation (3).

$$V_{OUT(OVP)} = V_{CC(OVP)} + V_{FD1} + V_{FD2} - V_{FD3} \quad (3)$$

where,

$V_{OUT(OVP)}$ is voltage of between $V_{OUT(+)}$ and $V_{OUT(-)}$,

V_{FD1} is the forward voltage of D1 in Figure 8-1,

V_{FD2} is the forward voltage of D2, and

V_{FD3} is the forward voltage of D3.

8.10 Thermal Shutdown (TSD)

Figure 8-16 shows the Thermal Shutdown (TSD) operational waveforms.

When the junction temperature of the IC control circuit increases to $T_{j(TSD)} = 135$ °C (min.) or more, the TSD is activated, and the IC stops switching operation. The TSD has a temperature hysteresis. While the junction temperature of the control circuit is more than $T_{j(TSD)} - T_{j(TSD)HYS}$, the Bias Assist Function is enabled when VCC pin voltage decreases to about 9.4 V. While this function is activated, the startup current is supplied to VCC pin in order to keep $V_{CC(OFF)}$ or more, and the IC holds stopping.

While the junction temperature is $T_{j(TSD)} - T_{j(TSD)HYS}$ or less, the Bias Assist Function is disabled, and VCC pin voltage decreases to $V_{CC(OFF)}$ or less. Thus, the control circuit stops operation. After that, the startup circuit is activated, VCC pin voltage increases to $V_{CC(ON)}$ by the startup current, and the control circuit operates again. The intermittent operation by TSD and UVLO is repeated in the TSD state.

After the fault condition is removed, the IC returns to normal operation automatically.

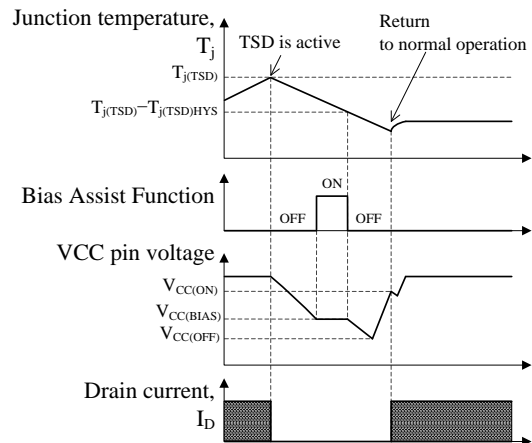

Figure 8-16. TSD Operational Waveforms

9. Design Notes

9.1 External Components

Take care to use properly rated, including derating as necessary, and proper type of components.

Figure 9-1 shows the peripheral circuit of IC in Buck converter. The pin number of SOIC8 package products in the circuits is shown in bracket.

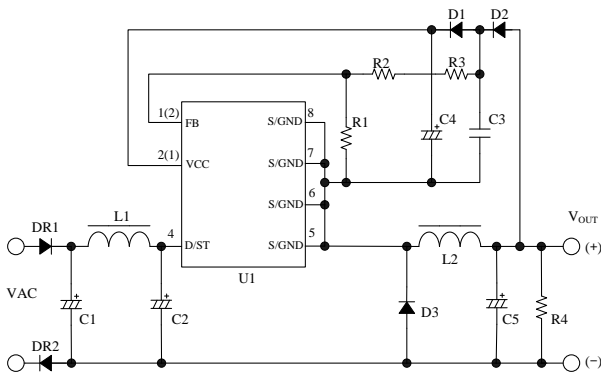

Figure 9-1. Peripheral Circuit of IC in Buck Converter

9.1.1 Input and Output Electrolytic Capacitor

Apply proper derating to ripple current, voltage, and temperature rise.

The value of output electrolytic capacitor, C5, should be fulfilled the following conditions:

- The specification of output ripple
- Enough shorter output voltage rising time in startup than the OLP Delay Time at Startup, $t_{OLP} = 72$ ms.
- Low impedance types, designed for switch mode power supplies, is recommended.

The ESR of C5 should be set in the range of Equation (4).

$$Z_{CO} < \frac{\Delta V_{OR}}{I_{LRP}} \quad (4)$$

where,

Z_{CO} is the ESR of electrolytic capacitor at the operation frequency (Since the ESR in general catalogs is mostly measured at 100 kHz, check the frequency characteristic.),

ΔV_{OR} is the output ripple voltage specification, and I_{LRP} is the ripple current of inductor (Refer to Section 9.3).

9.1.2 Inductor

Apply proper design margin to core temperature rise by core loss and copper loss.

The inductor should be designed so that the inductor current does not saturate. Refer Section 9.3 about the inductance. The value should be the minimum considered a negative tolerance of inductance and a decline of DC superposition characteristics.

The on-time must be longer than the Leading Edge Blanking Time to control the output voltage constantly.

In the universal input voltage design, the on-time is easy to become short in the condition of maximum AC input voltage and light load. Be careful not to choose too small value for the inductance (The recommended value is 600 μ H or more).

9.1.3 VCC Pin Peripheral Circuit

The reference value of C4 in Figure 9-1 is generally 10 to 47 μ F. Refer to Section 8.1 about the startup time.

9.1.4 FB Pin Peripheral Circuit

As shown in Figure 9-1, FB pin is input the voltage divided the voltage between $V_{OUT}(+)$ and S/GND pin by resistors.

C3 is the smoothing capacitor. The value of C3 depends on the value of output electrical capacitor, C5. Usually the value of C3 is 0.022 μ F to 0.22 μ F. When C3 value is set larger, the line regulation becomes better, however, the dynamic response of the output voltage becomes worse. Be careful of that value.

The voltage dividing resistor of R1, R2 and R3 is determined by the reference voltage, $V_{FB(REF)} = 2.50$ V, the output voltage, V_{OUT} , and so on. The following Equation (5) shows the relationship of them.

The target value of R1 is about 10 k Ω to 22 k Ω . R2 and R3 should be adjusted in actual operation condition.

The V_F of D2 and D3 affects the output voltage. Thus, the diodes of low V_F should be selected.

$$|V_{OUT}| \cong V_{FB(REF)} \times \frac{R1 + R2 + R3}{R1} + V_{FD2} - V_{FD3}$$

$$\Rightarrow R2 + R3 = \left(\frac{|V_{OUT}| - V_{FD2} + V_{FD3}}{V_{FB(REF)}} - 1 \right) \times R1 \quad (5)$$

where,

V_{FD2} is the forward voltage of D2, and V_{FD3} is the forward voltage of D3.

9.1.5 Freewheeling diode

D3 in Figure 9-1 is the freewheeling diode.

When the internal power MOSFET turns on, the recovery current flows through D3. The current affects power loss and noise much. The V_F affects the output voltage. Thus, the diode of fast recovery and low V_F should be selected.

9.1.6 Bleeder resistance

For light load application, the bleeder resistor, R4, in Figure 9-1 should be connected to both ends of output capacitor, C5, to prevent the increase of output voltage.

The value of R4 should be satisfied with Equation (6), and should be adjusted in actual operation condition.

$$R4 \leq \frac{|V_{OUT}|}{3mA} \quad (6)$$

9.2 D/ST Pin

When the D/ST pin voltage and the current exceed the Absolute Maximum Ratings, the internal power MOSFET connected to D/ST pin would be permanently damaged.

The D/ST pin voltage should be less than 630 V which is the derating value of 90 % for the Absolute Maximum Ratings, 700 V, in all condition of actual operation, and the parameters of transformer and components value should be selected based on actual operation in the application.

In addition, the D/ST pin voltage should be less than 560 V in the steady state operation.

9.3 Inductance Calculation

Since this calculation is just on paper, it is necessary to take account of margins and to check operations on actual operation in the application.

The PWM control has the three operation modes shown in Figure 9-2. Since each operation mode has that characteristic, it is necessary to take account of choosing the operation mode.

The table on the right shows the comparison of three operation modes in the same input and output condition.

Table 9-1. Operation Mode Comparison

	P _{OW}	L	I _{LR}	P _{RD(ON)}	P _{SW}
CCM	Large	Large	Small	Small	Large
CRM	Middle	Middle	Middle	Middle	Small
DCM	Small	Small	Large	Large	Small

where,
 CCM is continuous current mode,
 CRM is critical current mode,
 DCM is discontinuous current mode,
 P_{OW} is capable output power,
 L is inductance value of L2,
 I_{LR} is ripple inductor current,
 P_{RDS(ON)} is conduction loss on the power MOSFET,
 P_{SW} is switching loss.

9.3.1 Parameter Definition

The following parameters refer to the circuit of Figure 6-1. Buck Converter and Figure 6-2. Inverting Converter.

- V_{DCIN_MIN} is minimum DC input voltage at C2,
- V_{DCIN_MAX} is maximum DC input voltage at C2,
- V_{OUT} is output voltage,
- I_{OUT} is output current,
- V_{RON} is on voltage of internal power MOSFET,
 Drain current × R_{DS(ON)},
- V_{FD1} is D1 forward voltage,
- V_{FD2} is D2 forward voltage,
- V_{FD3} is D3 forward voltage,
- V_{DZ1} is DZ1 zener voltage.

When |V_{OUT}| is 27.5 V or more, add a zener diode or a regulator. Take care of that power loss.

When the following have no values, see the values of Section 2. Electrical Characteristics.

- D_{ON_MAX} is maximum on-duty in steady operation, 0.5,
- K_{RP_MIN} is 0.4,
- V_{ST_MAX} is maximum value of V_{ST(ON)},
- V_{DC(MAX)} is maximum DC input voltage, recommended value is 400 V,
- V_{CC_MIN} is minimum value of VCC Voltage, 10 V,
- V_{CC(OVP)_MIN} is minimum value of V_{CC(OVP)},
- I_{DLIM_MIN} is minimum value of I_{DLIM},
- I_{DLIM_TYP} is typical value of I_{DLIM},
- f_{TYP} is typical value of f_{OSC(AVG)},
- f_{MIN} is minimum switching frequency, 23 kHz,
- I_{DSTB} is typical value of I_{DSTB}.

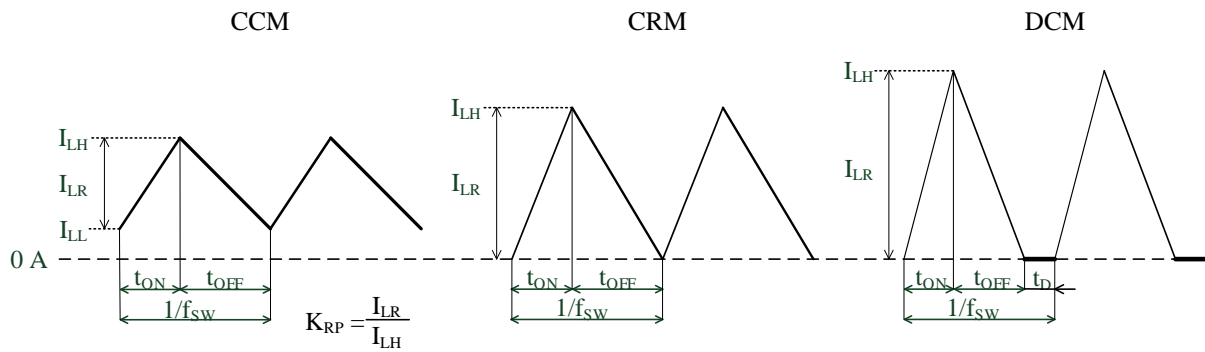

Figure 9-2. Operation Mode of PWM Control

where,
 f_{SW} is switching frequency, t_{ON} is on-time, t_{OFF} is off-time, t_D is discontinuous current time,
 I_{LH} is upper inductor current, I_{LL} is lower inductor current, I_{LR} is ripple inductor current,
 K_{RP} is ripple inductor current ratio, I_{LR}/I_{LH}.

9.3.2 Buck Converter

(B-1) Input and Output Condition

The definition refers to Section 9.3.1.

V_{DCIN_MIN}	Lower value is a higher value or more of either V_{ST_MAX} or $2 \times V_{OUT} + V_{FD3} + V_{RON}$. Upper value is $V_{DC(MAX)}$ or less.
V_{DCIN_MAX}	$V_{DCIN_MIN} \leq V_{DCIN_MAX} < V_{DC(MAX)}$
V_{OUT}	$V_{CC_MIN} + V_{DZ1} - V_{FD3} + (V_{FD1} + V_{FD2}) < V_{OUT} < 0.5 \times (V_{DCIN_MIN} - V_{RON} - V_{FD3})$
I_{OUT}	$I_{OUT} < 0.8 \times I_{DLIM_MIN}$
V_{DZ1}	Lower value is a higher value or more of either 0 or $V_{OUT} + V_{FD3} - (V_{FD1} + V_{FD2} + V_{CC(OVP)_MIN})$. Upper value is $V_{OUT} + V_{FD3} - (V_{FD1} + V_{FD2} + V_{CC_MIN})$

(B-2) Calculation

There are two calculation ways: L_{CALC} Calculation, and Parameter Calculation assigned L_{USER} .

(B-2-1) L_{CALC} Calculation

The inductance, L_{CALC} , is given by choosing the operation mode at V_{DCIN_MIN} . The parameters of both V_{DCIN_MIN} and V_{DCIN_MAX} are given by L_{CALC} .

(B-2-1-1) Parameters for V_{DCIN_MIN}

(B-2-1-1-1) On-duty in Continuous Operation, D_{CCM1}

$$D_{CCM1} = \frac{V_{OUT} + V_{FD3}}{V_{DCIN_MIN} - V_{RON} + V_{FD3}}$$

The condition of $D_{CCM1} : < 0.5$

(B-2-1-1-2) Choosing the Operation Mode, and K_{RP1} or D_{DCM1}

• Choosing CCM

K_{RP1} is set in the following range.

$$0.4 \leq K_{RP1} < 2 \times \frac{I_{DLIM_MIN} - I_{OUT}}{I_{DLIM_MIN}} < 1$$

The condition of $I_{OUT} : < 0.8 \times I_{DLIM_MIN}$

• Choosing CRM

The condition of $I_{OUT} : \leq 0.5 \times I_{DLIM_MIN}$

• Choosing DCM

The on-duty for DCM, D_{DCM1} , is set in the following range.

$$\frac{2 \times I_{OUT} \times D_{CCM1}}{I_{DLIM_MIN}} \leq D_{DCM1} < D_{CCM1}$$

The condition of $I_{OUT} : < 0.5 \times I_{DLIM_MIN}$

(B-2-1-1-3) Inductor Current

D_{ON1} is denoted the on-duty. I_{LH1} , I_{LL1} , and I_{LR1} are the upper inductor current, the lower inductor current, and the ripple inductor current, respectively.

• Choosing CCM

$$D_{ON1} = D_{CCM1}$$

$$I_{LH1} = \frac{2 \times I_{OUT}}{2 - K_{RP1}}$$

$$I_{LR1} = K_{RP1} \times I_{LH1}$$

$$I_{LL1} = I_{LH1} - I_{LR1}$$

• Choosing CRM

$$D_{ON1} = D_{CCM1}$$

$$I_{LH1} = 2 \times I_{OUT}$$

$$I_{LR1} = I_{LH1}, I_{LL1} = 0$$

• Choosing DCM

$$D_{ON1} = D_{DCM1}$$

$$I_{LH1} = 2 \times I_{OUT} \times \frac{D_{CCM1}}{D_{DCM1}}$$

$$I_{LR1} = I_{LH1}, I_{LL1} = 0$$

(B-2-1-1-4) Switching Frequency, f_{SW1}

The f_{SW1} is given by the following with the I_{LH1} of the choosing operation mode.

- For $I_{LH1} \leq I_{DSTB}$, set to f_{MIN}
- For $I_{LH1} \geq 0.8 \times I_{DLIM_TYP}$, set to f_{TYP}
- For $I_{DSTB} < I_{LH1} < 0.8 \times I_{DLIM_TYP}$, set to

$$K \times (I_{LH1} - I_{DSTB}) + f_{MIM}$$

where, K is the following coefficient;

$$K = \left(\frac{f_{TYP} - f_{MIM}}{0.8 \times I_{DLIM_TYP} - I_{DSTB}} \right)$$

(B-2-1-1-5) On-time, t_{ON1}

By D_{ON1} and f_{SW1} of the choosing operation mode,

$$t_{ON1} = \frac{D_{ON1}}{f_{SW1}}$$

If t_{ON1} is less than 400 ns, try the following procedure 1 to increase it.

- Procedure 1 :
For CCM, reduce K_{RPI} or I_{OUT} .
For CRM, change to CCM.
For DCM, increase D_{DCM1} , or change to CRM or CCM.
After these changes, try to calculate again from Section (B-1) Input and Output Condition.

(B-2-1-1-6) Inductance, L_{CALC}

By I_{LH1} , I_{LL1} , and f_{SW1} of the choosing operation mode,

$$L_{CALC} = \frac{2 \times I_{OUT} \times (V_{OUT} + V_{FD3}) \times (1 - D_{CCM1})}{(I_{LH1}^2 - I_{LL1}^2) \times f_{SW1}}$$

The value should be the minimum considered a negative tolerance of inductance and a decline of DC superposition characteristics.

If L_{CALC} is less than 600 μ H, try the procedure 1 of Section (B-2-1-1-5) to increase it.

(B-2-1-1-7) Drain RMS Current and Inductor RMS current : I_{DRMS1} , I_{LRMS1}

$$I_{DRMS1} = \sqrt{\left(\frac{1}{3} \times (I_{LH1} - I_{LL1})^2 + I_{LH1} \times I_{LL1} \right) \times D_{ON1}}$$

The conduction loss of $R_{DS(ON)}$ of power MOSFET is

estimated to be $I_{DRMS1}^2 \times R_{DS(ON)}$.

$$I_{LRMS1} = \sqrt{\left(\frac{1}{3} \times (I_{LH1} - I_{LL1})^2 + I_{LH1} \times I_{LL1} \right) \times \frac{D_{ON1}}{D_{CCM1}}}$$

This value is equivalent to the rating for inductor.

(B-2-1-2) Parameters for V_{DCIN_MAX}

(B-2-1-2-1) On-duty in Continuous Operation, D_{CCM2}

$$D_{CCM2} = \frac{V_{OUT} + V_{FD3}}{V_{DCIN_MAX} - V_{RON} + V_{FD3}}$$

The condition of $D_{CCM2} : < 0.5$

(B-2-1-2-2) Operation Mode Check

1) At first, calculate the following coefficients

L_{CALC} given in Section (B-2-1-1-6) is used.

$$K = \left(\frac{f_{TYP} - f_{MIM}}{0.8 \times I_{DLIM_TYP} - I_{DSTB}} \right)$$

$$M2 = \frac{2 \times I_{OUT} \times (V_{OUT} + V_{FD3}) \times (1 - D_{CCM2})}{L_{CALC}}$$

$$A = 4 \times I_{OUT} \times K$$

$$B = 4 \times I_{OUT} \times \{f_{MIM} - K \times (I_{DSTB} + I_{OUT})\}$$

$$C = -4 \times I_{OUT}^2 \times (f_{MIM} - K \times I_{DSTB}) - M2$$

2) Calculate Upper inductor current, I_{LH2}

$$I_{LH2} = \frac{1}{2 \times A} \times \left(-B + \sqrt{B^2 - 4 \times A \times C} \right)$$

3) Calculate Switching Frequency, f_{SW2}

$$f_{SW2} = K \times (I_{LH2} - I_{DSTB}) + f_{MIN}$$

where,

For $f_{SW2} < f_{MIN}$, set to f_{MIN} .

For $f_{TYP} < f_{SW2}$, set to f_{TYP} .

When f_{SW2} is f_{MIN} or f_{TYP} , calculate I_{LH2} again by the following.

$$I_{LH2} = \frac{M2}{4 \times I_{OUT} \times f_{SW2}} + I_{OUT}$$

For $f_{MIN} \leq f_{SW2} \leq f_{TYP}$, I_{LH2} is the value of the previous 2).

If I_{LH2} is I_{DLIM_MIN} or more, try the procedure 1 in Section (B-2-1-1-5) to decrease it.

4) Calculate Lower inductor current, I_{LL2}

$$I_{LL2} = 2 \times I_{OUT} - I_{LH2}$$

5) The operation mode is given by the following.

- For $I_{LL2} > 0$, CCM
- For $I_{LL2} = 0$, CRM
- For $I_{LL2} < 0$, DCM

(B-2-1-2-3) D_{ON2} , f_{SW2} , I_{LH2} , I_{LL2} of the Operation Mode Result

These parameters are different in the operation mode results of Section (B-2-1-2-2)-5).

- Resulting in CCM

$$D_{ON2} = D_{CCM2}$$

f_{SW2} is the value of Section (B-2-1-2-2)-3).

I_{LH2} is the value of Section (B-2-1-2-2)-3).

I_{LL2} is the value of Section (B-2-1-2-2)-4).

$$I_{LR2} = I_{LH2} - I_{LL2}$$

$$K_{RP2} = \frac{I_{LR2}}{I_{LH2}}$$

- Resulting in CRM

$$D_{ON2} = D_{CCM2}$$

f_{SW2} is the value of Section (B-2-1-2-2) - 3).

$$I_{LH2} = 2 \times I_{OUT}$$

$$I_{LR2} = I_{LH2}, I_{LL2} = 0$$

- Resulting in DCM

1) Draw the graph of the following equations.

By using this, find the values of f_{SW2} and I_{LH2} of DCM.

$$I_{LH2_f} = \frac{f_{SW2} - f_{MIN}}{K} + I_{DSTB}$$

$$I_{LH2_DCM} = \sqrt{\frac{M2}{f_{SW2}}}$$

$$I_{LH2_CRM} = 2 \times I_{OUT}$$

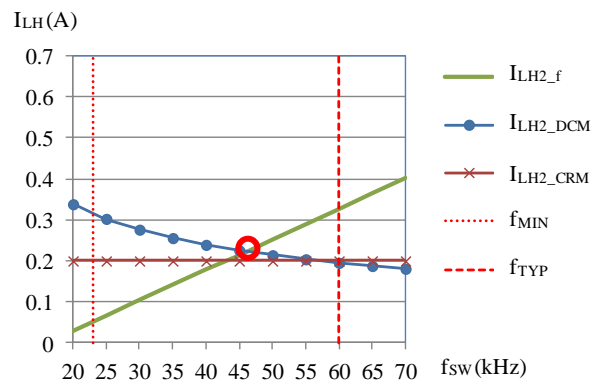

Figure 9-3. I_{LH2} and f_{SW2} of DCM Graph in which the intersection of I_{LH_f} and I_{LH_DCM} is in the range of f_{MIN} to f_{TYP} .

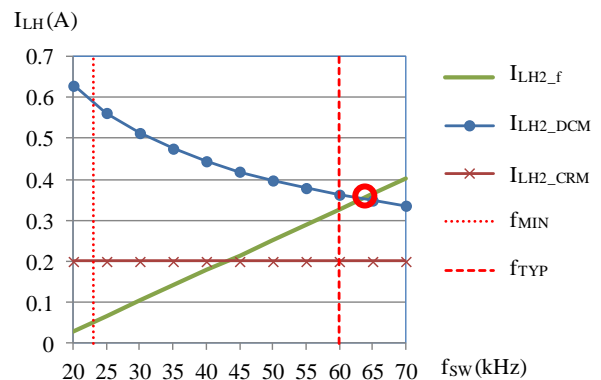

Figure 9-4. I_{LH2} and f_{SW2} of DCM Graph in which the intersection of I_{LH_f} and I_{LH_DCM} is out of the range of f_{MIN} to f_{TYP} .

In DCM, I_{LH} value at the intersection of I_{LH2_f} and I_{LH2_DCM} is bigger than that of I_{LH2_CRM} .

2) Set Switching Frequency, f_{SW2}

When f_{SW} at the intersection of I_{LH2_f} and I_{LH2_DCM} is in the range of f_{MIN} to f_{TYP} as shown in Figure 9-3, f_{SW2} is set to that value. When f_{SW} is out of the range as shown in Figure 9-4, f_{SW2} is set to the limited value which is f_{MIN} or f_{TYP} of the over range side.

3) Calculate On-duty, D_{ON2}

$$D_{ON2} = D_{DCM2} = 2 \times I_{OUT} \times D_{CCM2} \times \sqrt{\frac{f_{SW2}}{M2}}$$

The condition of $D_{DCM2} : < D_{CCM2}$

4) Calculate I_{LH2} , I_{LL2} , and I_{LR2}

I_{LH2} is the value at the intersection of f_{SW2} which is given in the previous 2) and I_{LH2_DCM} . Otherwise, I_{LH2} is given below.

$$I_{LH2} = 2 \times I_{OUT} \times \frac{D_{CCM2}}{D_{DCM2}}$$

$$I_{LR2} = I_{LH2}, I_{LL2} = 0$$

(B-2-1-2-4) I_{LH2}

If I_{LH2} is I_{DLIM_MIN} or more, try the procedure 1 in Section (B-2-1-1-5) to decrease it.

(B-2-1-2-5) On-time, t_{ON2}

$$t_{ON2} = \frac{D_{ON2}}{f_{SW2}}$$

If t_{ON2} is less than 400 ns, try the procedure 1 in Section (B-2-1-1-5) to increase it.

(B-2-1-2-6) I_{DRMS2} , I_{LRMS2}

These are given by substituting I_{LH2} , I_{LL2} , D_{ON2} , and D_{CCM2} for I_{LH1} , I_{LL1} , D_{ON1} , and D_{CCM1} in the equation of Section (B-2-1-1-7), respectively.

(B-2-1-3) Inductor Current specification

The saturation current of the inductor should be enough larger than I_{DLIM_MAX} .

The rating current refers to the equation of RMS in Section (B-2-1-1-7).

(B-2-2) Parameter Calculation Assigned L_{USER}

Parameter calculation assigned L_{USER} at V_{DCIN_MIN} and V_{DCIN_MAX} is similar to the way of Section (B-2-1-2)..

Parameters assigned L_{USER} are given by substituting the input voltage and L_{USER} for V_{DCIN_MAX} and L_{CALC} .

If the conditions of calculation aren't satisfied, increase L_{USER} setting, or decrease I_{OUT} setting, and then try to calculate again.

9.3.3 Inverting Convertor

(I-1) Input and Output Condition

The definition refers to Section 9.3.1. $|V_{OUT}|$ is the absolute value of V_{OUT} .

V_{DCIN_MIN}	Lower value is a higher value or more of either V_{ST_MAX} or $V_{OUT} + V_{FD3} + V_{RON}$. Upper value is $V_{DC(MAX)}$ or less.
V_{DCIN_MAX}	$V_{DCIN_MIN} \leq V_{DCIN_MAX} < V_{DC(MAX)}$
$ V_{OUT} $	$V_{CC_MIN} + V_{DZ1} - V_{FD3} + (V_{FD1} + V_{FD2}) < V_{OUT} < V_{DCIN_MIN} - V_{RON} - V_{FD3}$
I_{OUT}	$I_{OUT} < 0.8 \times I_{DLIM_MIN} \times (1 - D_{CCM1})$ where, $D_{CCM1} = \frac{V_{OUT} + V_{FD3}}{V_{DCIN_MIN} - V_{RON} + V_{OUT} + V_{FD3}}$
V_{DZ1}	Lower value is a higher value or more of either 0 or $V_{OUT} + V_{FD3} - (V_{FD1} + V_{FD2} + V_{CC(OVP)_MIN})$. Upper value is $V_{OUT} + V_{FD3} - (V_{FD1} + V_{FD2} + V_{CC_MIN})$.

(I-2) Calculation

There are two calculation ways: L_{CALC} Calculation, and Parameter Calculation assigned L_{USER} .

(I-2-1) L_{CALC} Calculation

The inductance, L_{CALC} , is given by choosing the operation mode at V_{DCIN_MIN} . The parameters of both V_{DCIN_MIN} and V_{DCIN_MAX} are given by L_{CALC} .

(I-2-1-1) Parameters for V_{DCIN_MIN}

(I-2-1-1-1) On-duty in Continuous Operation, D_{CCM1} , and Average Inductor Current, I_{LAVG1}

$$D_{CCM1} = \frac{V_{OUT} + V_{FD3}}{V_{DCIN_MIN} - V_{RON} + V_{OUT} + V_{FD3}}$$

The condition of D_{CCM1} : < 0.5

$$I_{LAVG1} = \frac{I_{OUT}}{1 - D_{CCM1}}$$

(I-2-1-1-2) Choosing the Operation Mode, and K_{RP1} or D_{DCM1}

- Choosing CCM

K_{RP1} is set in the following range.

$$0.4 \leq K_{RP1} < 2 \times \left(1 - \frac{I_{LAVG1}}{I_{DLIM_MIN}} \right) < 1$$

The condition of I_{OUT} :

$$< 0.8 \times I_{DLIM_MIN} \times (1 - D_{CCM1})$$

- Choosing CRM

The condition of I_{OUT} :

$$\leq 0.5 \times I_{DLIM_MIN} \times (1 - D_{CCM1})$$

- Choosing DCM

On-duty, D_{DCM1} , is set in the following range.

$$\frac{2 \times I_{LAVG1} \times D_{CCM1}}{I_{DLIM_MIN}} \leq D_{DCM1} < D_{CCM1}$$

The condition of I_{OUT} :

$$< 0.5 \times I_{DLIM_MIN} \times (1 - D_{CCM1})$$

(I-2-1-1-3) Inductor Current

D_{ON1} is denoted the on-duty. I_{LH1} , I_{LL1} , and I_{LR1} are the upper inductor current, the lower inductor current, and the ripple inductor current, respectively.

- Choosing CCM

$$D_{ON1} = D_{CCM1}$$

$$I_{LH1} = \frac{2 \times I_{LAVG1}}{2 - K_{RP1}}$$

$$I_{LR1} = K_{RP1} \times I_{LH1}$$

$$I_{LL1} = I_{LH1} - I_{LR1}$$

- Choosing CRM

$$D_{ON1} = D_{CCM1}$$

$$I_{LH1} = 2 \times I_{LAVG1}$$

$$I_{LR1} = I_{LH1}, I_{LL1} = 0$$

- Choosing DCM

$$D_{ON1} = D_{DCM1}$$

$$I_{LH1} = 2 \times I_{LAVG1} \times \frac{D_{CCM1}}{D_{DCM1}}$$

$$I_{LR1} = I_{LH1}, I_{LL1} = 0$$

(I-2-1-1-4) Switching Frequency, f_{SW1}

The f_{SW1} is given by the following with the I_{LH1} of the choosing operation mode.

- For $I_{LH1} \leq I_{DSTB}$, set to f_{MIN}
- For $I_{LH1} \geq 0.8 \times I_{DLIM_TYP}$, set to f_{TYP}
- For $I_{DSTB} < I_{LH1} < 0.8 \times I_{DLIM_TYP}$, set to

$$K \times (I_{LH1} - I_{DSTB}) + f_{MIM}$$

where, K is the following coefficient;

$$K = \left(\frac{f_{TYP} - f_{MIN}}{0.8 \times I_{DLIM_TYP} - I_{DSTB}} \right)$$

(I-2-1-1-5) On-time, t_{ON1}

By D_{ON1} and f_{SW1} of the choosing operation mode,

$$t_{ON1} = \frac{D_{ON1}}{f_{SW1}}$$

If t_{ON1} is less than 400 ns, try the following procedure 1 to increase it.

- Procedure 1 :
For CCM, reduce K_{RP1} or I_{OUT} .
For CRM, change to CCM.
For DCM, increase D_{DCM1} , or change to CRM or CCM.
After these changes, try to calculate again from Section (I-1) Input and Output Condition.

(I-2-1-1-6) Inductance, L_{CALC}

By I_{LH1} , I_{LL1} , and f_{SW1} of the choosing operation mode,

$$L_{CALC} = \frac{2 \times I_{OUT} \times (V_{OUT} + V_{FD3})}{(I_{LH1}^2 - I_{LL1}^2) \times f_{SW1}}$$

The value should be the minimum considered a negative tolerance of inductance and a decline of DC superposition characteristics.

If L_{CALC} is less than 600 μ H, try the procedure 1 of Section (I-2-1-1-5) to increase it.

The saturation current of the inductor should be enough larger than I_{DLIM_MAX} .

(I-2-1-1-7) Drain RMS Current and Inductor RMS Current : I_{DRMS1} , I_{LRMS1}

$$I_{DRMS1} = \sqrt{\left(\frac{1}{3} \times (I_{LH1} - I_{LL1})^2 + I_{LH1} \times I_{LL1} \right) \times D_{ON1}}$$

The conduction loss of $R_{DS(ON)}$ of power MOSFET is estimated to be $I_{DRMS1}^2 \times R_{DS(ON)}$.

$$I_{LRMS1} = \sqrt{\left(\frac{1}{3} \times (I_{LH1} - I_{LL1})^2 + I_{LH1} \times I_{LL1} \right) \times \frac{D_{ON1}}{D_{CCM1}}}$$

This value is equivalent to the rating for inductor.

(I-2-1-2) Parameters for V_{DCIN_MAX}

(I-2-1-2-1) On-duty in Continuous Operation, D_{CCM2} , and Average Inductor Current, I_{LAVG2}

$$D_{CCM2} = \frac{V_{OUT} + V_{FD3}}{V_{DCIN_MAX} - V_{RON} + V_{OUT} + V_{FD3}}$$

The condition of $D_{CCM2} : < 0.5$

$$I_{LAVG2} = \frac{I_{OUT}}{1 - D_{CCM2}}$$

(I-2-1-2-2) Operation Mode Check

1) At first, calculate the following coefficients

L_{CALC} given in Section (I-2-1-1-6) is used.

$$K = \left(\frac{f_{TYP} - f_{MIN}}{0.8 \times I_{DLIM_TYP} - I_{DSTB}} \right)$$

$$M2 = \frac{2 \times I_{LAVG2} \times (V_{OUT} + V_{FD3}) \times (1 - D_{CCM2})}{L_{CALC}}$$

$$A = 4 \times I_{LAVG2} \times K$$

$$B = 4 \times I_{LAVG2} \times \{f_{MIM} - K \times (I_{DSTB} + I_{LACG2})\}$$

$$C = -4 \times I_{LAVG2}^2 \times (f_{MIM} - K \times I_{DSTB}) - M2$$

2) Calculate Upper inductor current, I_{LH2}

$$I_{LH2} = \frac{1}{2 \times A} \times \left(-B + \sqrt{B^2 - 4 \times A \times C} \right)$$

3) Calculate Switching frequency, f_{SW2}

$$f_{SW2} = K \times (I_{LH2} - I_{DSTB}) + f_{MIN}$$

where,

For $f_{SW2} < f_{MIN}$, set to f_{MIN} .

For $f_{TYP} < f_{SW2}$, set to f_{TYP} .

When f_{SW2} is f_{MIN} or f_{TYP} , calculate I_{LH2} again by the following.

$$I_{LH2} = \frac{M2}{4 \times I_{LAVG2} \times f_{SW2}} + I_{LAVG2}$$

For $f_{MIN} \leq f_{SW2} \leq f_{TYP}$, I_{LH2} is the value of the previous 2).

If I_{LH2} is I_{DLIM_MIN} or more, try the procedure 1 in Section (I-2-1-1-5) to decrease it.

4) Calculate Lower inductor current, I_{LL2}

$$I_{LL2} = 2 \times I_{LAVG2} - I_{LH2}$$

5) The operation mode is given by the following.

- For $I_{LL2} > 0$, CCM
- For $I_{LL2} = 0$, CRM
- For $I_{LL2} < 0$, DCM

(I-2-1-2-3) D_{ON2} , f_{SW2} , I_{LH2} , I_{LL2} of the Operation Mode Result

These parameters are different in the operation mode results of Section (I-2-1-2-2)-5).

- Resulting in CCM

$$D_{ON2} = D_{CCM2}$$

f_{SW2} is the value of Section (I-2-1-2-2)-3).

I_{LH2} is the value of Section (I-2-1-2-2)-3).

I_{LL2} is the value of Section (I-2-1-2-2)-4).

$$I_{LR2} = I_{LH2} - I_{LL2}$$

$$K_{RP2} = \frac{I_{LR2}}{I_{LH2}}$$

- Resulting in CRM

$$D_{ON2} = D_{CCM2}$$

f_{SW2} is the value of Section (I-2-1-2-2)-3).

$$I_{LH2} = 2 \times I_{LAVG2}$$

$$I_{LR2} = I_{LH2}, I_{LL2} = 0$$

- Resulting in DCM

1) Draw the graph of the following equations

By using this, find the values of f_{SW2} and I_{LH2} of DCM.

$$I_{LH2_f} = \frac{f_{SW2} - f_{MIN}}{K} + I_{DSTB}$$

$$I_{LH2_DCM} = \sqrt{\frac{M2}{f_{SW2}}}$$

$$I_{LH2_CRM} = 2 \times I_{LAVG2}$$

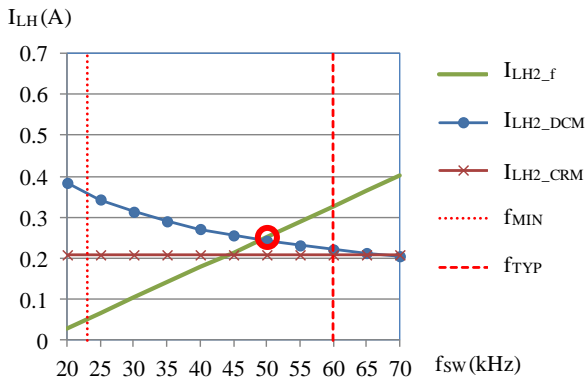

Figure 9-5. I_{LH2} and f_{SW2} of DCM Graph in which the intersection of I_{LH_f} and I_{LH_DCM} is in the range of f_{MIN} to f_{TYP} .

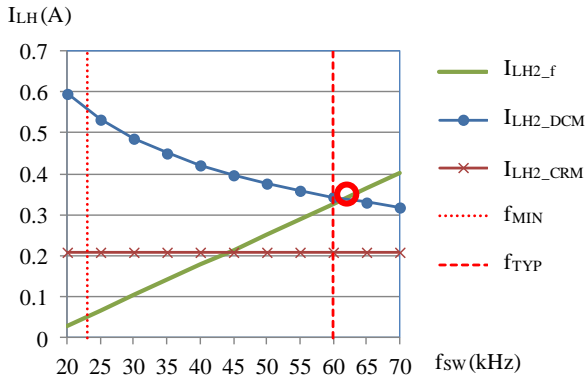

Figure 9-6. I_{LH2} and f_{SW2} of DCM Graph in which the intersection of I_{LH_f} and I_{LH_DCM} is out of the range of f_{MIN} to f_{TYP} .

In DCM, I_{LH} value at the intersection of I_{LH2_f} and I_{LH2_DCM} is bigger than that of I_{LH2_CRM} .

2) Set Switching frequency, f_{SW2}

When f_{SW} at the intersection of I_{LH2_f} and I_{LH2_DCM} is in the range of f_{MIN} to f_{TYP} as shown in Figure 9-5, f_{SW2} is set to that value. When f_{SW} is out of the range as shown in Figure 9-6, f_{SW2} is set to the limited value which is f_{MIN} or f_{TYP} of the over range side.

3) Calculate On-duty, D_{ON2}

$$D_{ON2} = D_{DCM2} = 2 \times I_{LAVG2} \times D_{CCM2} \times \sqrt{\frac{f_{SW2}}{M2}}$$

The condition of $D_{DCM2} : < D_{CCM2}$

4) Calculate I_{LH2} , I_{LL2} , and I_{LR2}

I_{LH2} is the value at the intersection of f_{SW2} which is given in the previous 2) and I_{LH2_DCM} . Otherwise, I_{LH2} is given below.

$$I_{LH2} = 2 \times I_{LAVG2} \times \frac{D_{CCM2}}{D_{DCM2}}$$

$$I_{LR2} = I_{LH2}, I_{LL2} = 0$$

(I-2-1-2-4) I_{LH2}

If I_{LH2} is I_{DLIM_MIN} or more, try the procedure 1 in Section (I-2-1-1-5) to decrease it.

(I-2-1-2-5) On-time, t_{ON2}

$$t_{ON2} = \frac{D_{ON2}}{f_{SW2}}$$

If t_{ON2} is less than 400 ns, try the procedure 1 in Section (I-2-1-1-5) to increase it.

(I-2-1-2-6) I_{DRMS2} , I_{LRMS2}

These are given by substituting I_{LH2} , I_{LL2} , D_{ON2} , and D_{CCM2} for I_{LH1} , I_{LL1} , D_{ON1} , and D_{CCM1} in the equation of Section (I-2-1-1-7), respectively.

(I-2-1-3) Inductor Current Specification

The saturation current of the inductor should be enough larger than I_{DLIM_MAX} .

The rating current refers to the equation of RMS in Section (I-2-1-1-7).

(I-2-2) Parameter Calculation Assigned L_{USER}

Parameter calculation assigned L_{USER} at V_{DCIN_MIN} and V_{DCIN_MAX} is similar to the way of Section (I-2-1-2) Parameters for V_{DCIN_MAX} .

Parameters assigned L_{USER} are given by substituting the input voltage and L_{USER} for V_{DCIN_MAX} and L_{CALC} .

If the conditions of calculation aren't satisfied, increase L_{USER} setting, or decrease I_{OUT} setting, and then try to calculate again.

9.4 PCB Trace Layout

Since the PCB circuit trace design and the component layout significantly affects operation, EMI noise, and power dissipation, the high frequency PCB trace should be low impedance with small loop and wide trace.

In addition, the ground traces affect radiated EMI noise, and wide, short traces should be taken into account.

Figure 9-7 and Figure 9-8 show the circuit design example.

- 1) Main Circuit Trace Layout
This is the main trace containing switching currents, and thus it should be as wide trace and small loop as possible.
- 2) Freewheeling Loop Layout
This is the trace for the current of freewheeling diode, D3, and thus it should be as wide trace and small loop as possible.
- 3) Control Ground Trace Layout
Since the operation of IC may be affected from the large current of the main trace that flows in control ground trace, the control ground trace should be separated from main trace and connected at single point grounding.

- 4) VCC Trace Layout
This is the trace for supplying power to the IC, and thus it should be as small loop as possible. If C4 and the IC are distant from each other, placing a capacitor such as film capacitor C_f (about 0.1 μF to 1.0 μF) close to the VCC pin and the S/GND pin is recommended.
- 5) FB Trace Layout
The divided voltage by R2+R3 and R1 of output voltage is input to the FB pin.
To increase the detection accuracy, R3 and R1 should be connected to the bottom of C3 and the S/GND pin, respectively. The trace between R1, R2 and the FB pin should be as short as possible.
- 6) Thermal Considerations
Since the internal power MOSFET has a positive thermal coefficient of R_{DS(ON)}, consider it in thermal design.
Since the copper area under the IC and the S/GND pin trace act as a heatsink, its traces should be as wide as possible.

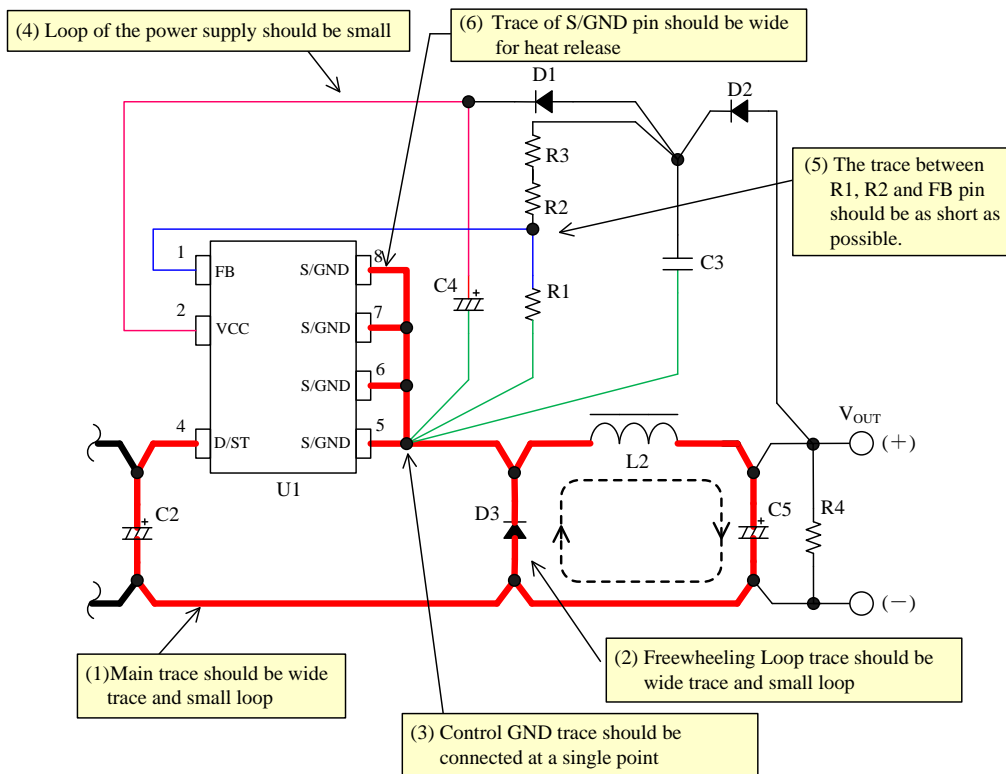

Figure 9-7. Peripheral circuit example around the IC for Buck converter (DIP8)

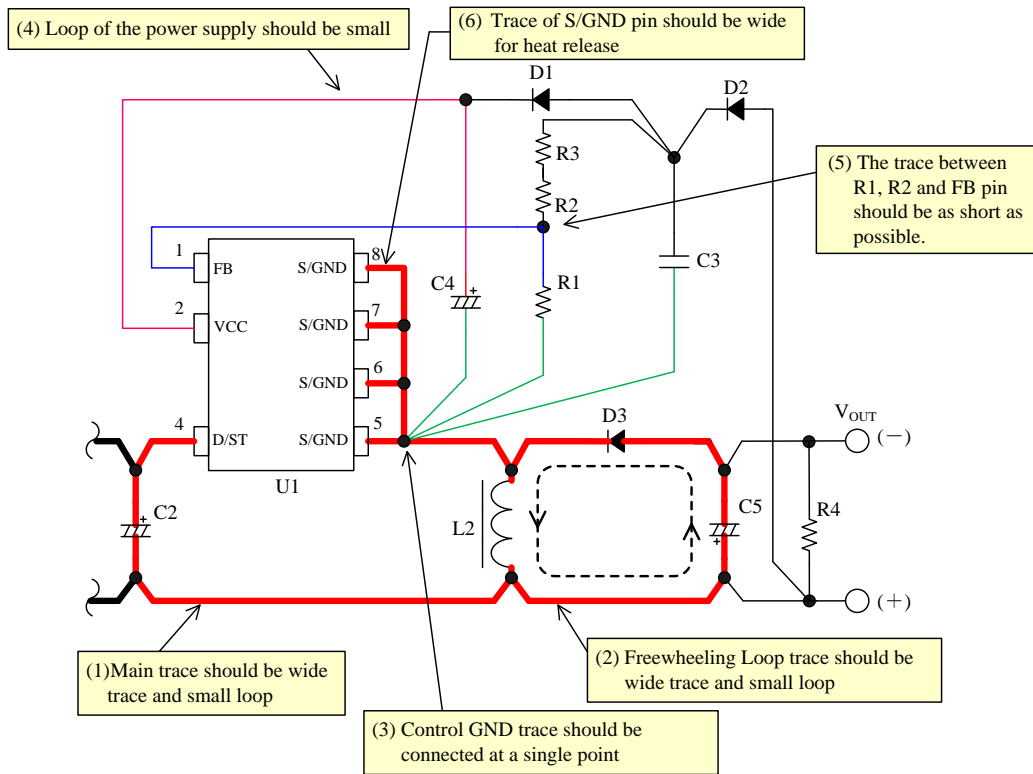

Figure 9-8. Peripheral circuit example around the IC for Inverting converter (DIP8)

10. Pattern Layout Example

10.1 Buck Converter

The following show the PCB pattern layout example and the circuit schematic using STR5A460D series of DIP8. Only parts in Figure 10-2 are used. The PCB pattern layout example for STR5A460S series of SOIC8 is the same except for some pin arrangements.

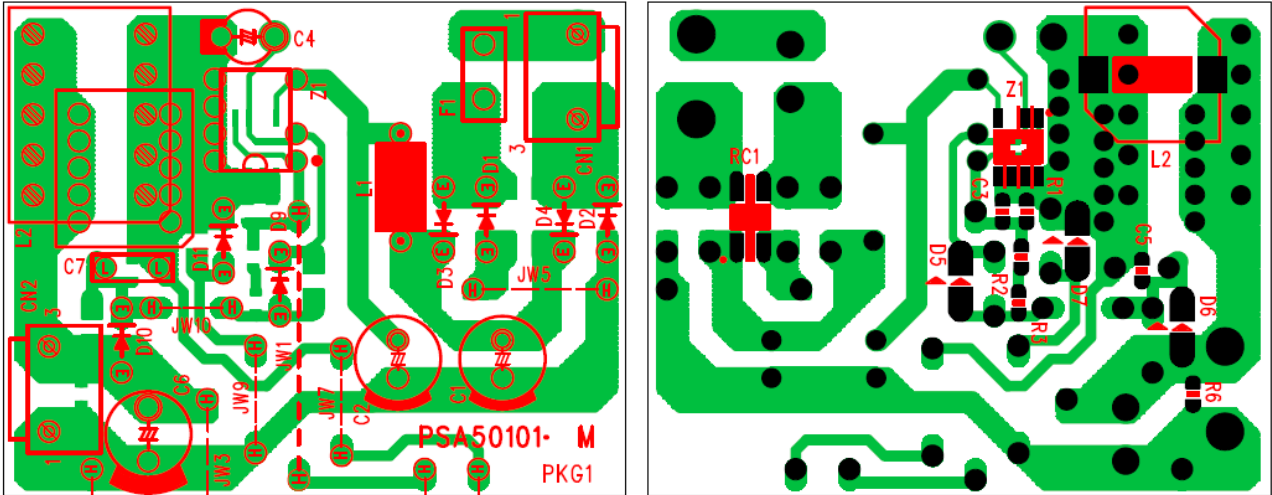

Figure 10-1. PCB pattern layout example for Buck converter

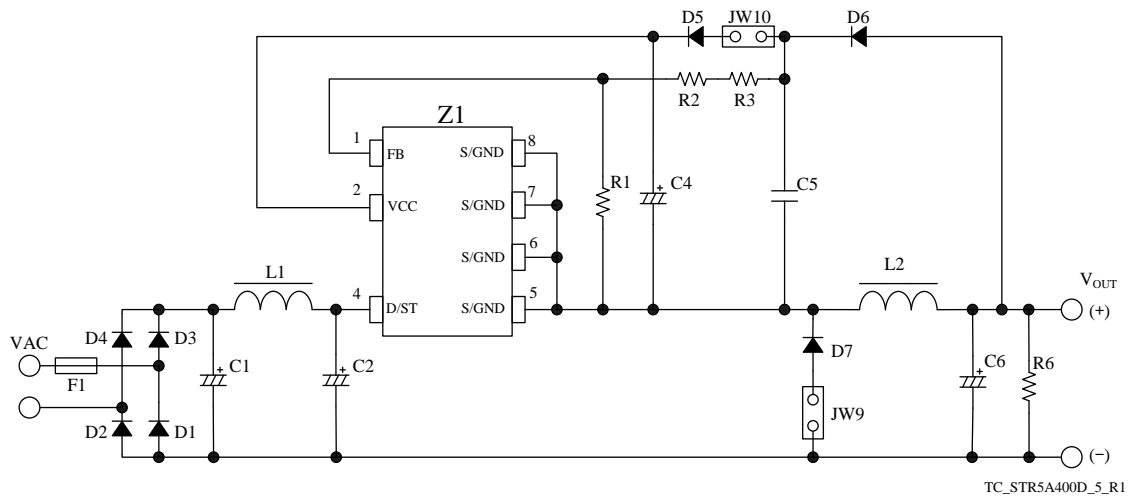

Figure 10-2. Circuit schematic for PCB pattern layout for Buck converter

10.2 Inverting Converter

The following show the PCB pattern layout example and the circuit schematic using STR5A460D series of DIP8. Only parts in Figure 10-4 are used.

The PCB pattern layout example for STR5A460S series of SOIC8 is the same except for some pin arrangements.

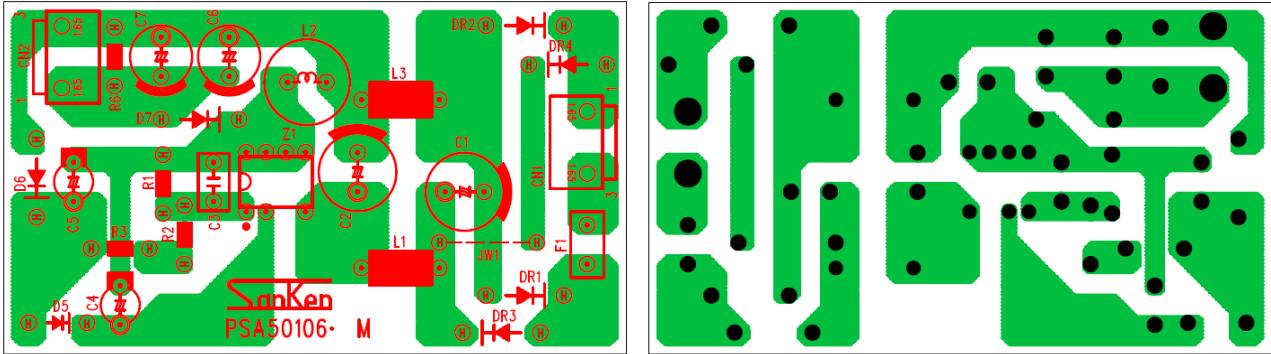

Figure 10-3. PCB pattern layout example for Inverting converter

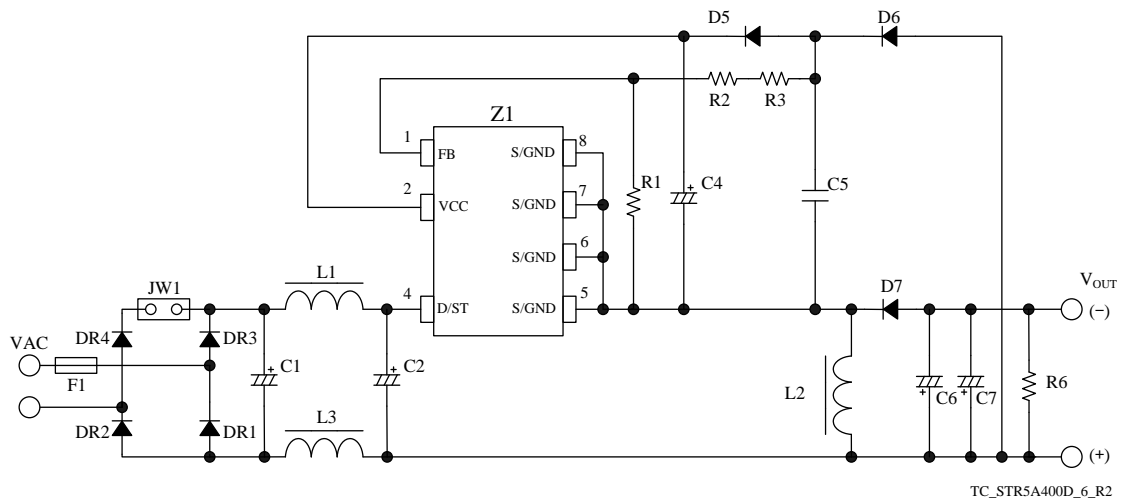

Figure 10-4. Circuit schematic for PCB pattern layout for Inverting converter

STR5A460 Series

11. Reference Design of Power Supply

11.1 Buck Converter

As an example, the following show the power supply specification, the circuit schematic, the bill of materials, and the transformer specification.

- Power supply specification

IC	STR5A464D
Input voltage	85 VAC to 265 VAC
Maximum output power	3 W (max.)
Output voltage	15 V
Output current	0.2 A

- Circuit schematic

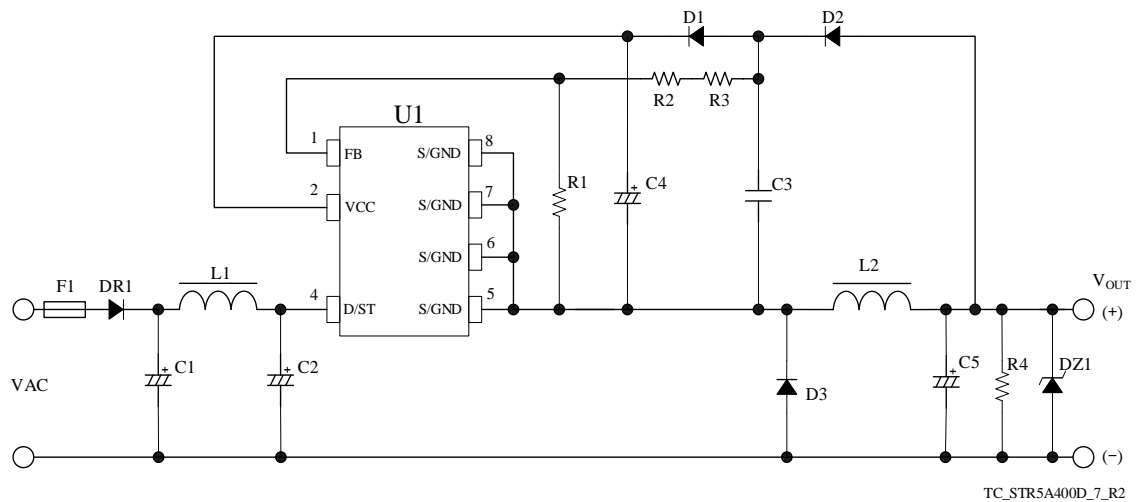

- Bill of materials

Symbol	Part type	Ratings ⁽¹⁾	Recommended Sanken Parts
DR1	General	1k V, 1 A	EM1C
F1	Fuse	250 V, 1 A	
L1 ⁽²⁾	CM inductor	330μH	
L2	Inductor	1 mH	
C1	Electrolytic	400 V, 8.2 μF	
C2	Electrolytic	400 V, 8.2 μF	
C3	Ceramic	50 V, 0.22 μF	
C4	Electrolytic	50 V, 10 μF	
C5	Electrolytic, Low impedance	25 V, 220 μF	
DZ1	Zener diode	V _Z = 18.8 V (min.)	SJPZ-E20
R1	General	10 kΩ	
R2 ⁽²⁾	General	47 kΩ	
R3 ⁽²⁾	General	4.7 kΩ	
R4 ⁽²⁾	General	6.8 kΩ, 1/4 W	
D1	Fast recovery	200V, 1 A	SJPL-D2
D2	Fast recovery	500 V, 1 A	SJPD-D5
D3	Fast recovery	500 V, 1 A	SJPD-D5
U1	IC		STR5A464D

⁽¹⁾ Unless otherwise specified, the voltage rating of capacitor is 50 V or less and the power rating of resistor is 1/8 W or less.

⁽²⁾ It is necessary to be adjusted based on actual operation in the application.

STR5A460 Series

11.2 Inverting Converter

As an example, the following show the power supply specification, the circuit schematic, the bill of materials, and the transformer specification.

- Power supply specification

IC	STR5A464D
Input voltage	85 VAC to 265 VAC
Maximum output power	3 W (max.)
Output voltage	- 15 V
Output current	0.2 A

- Circuit schematic

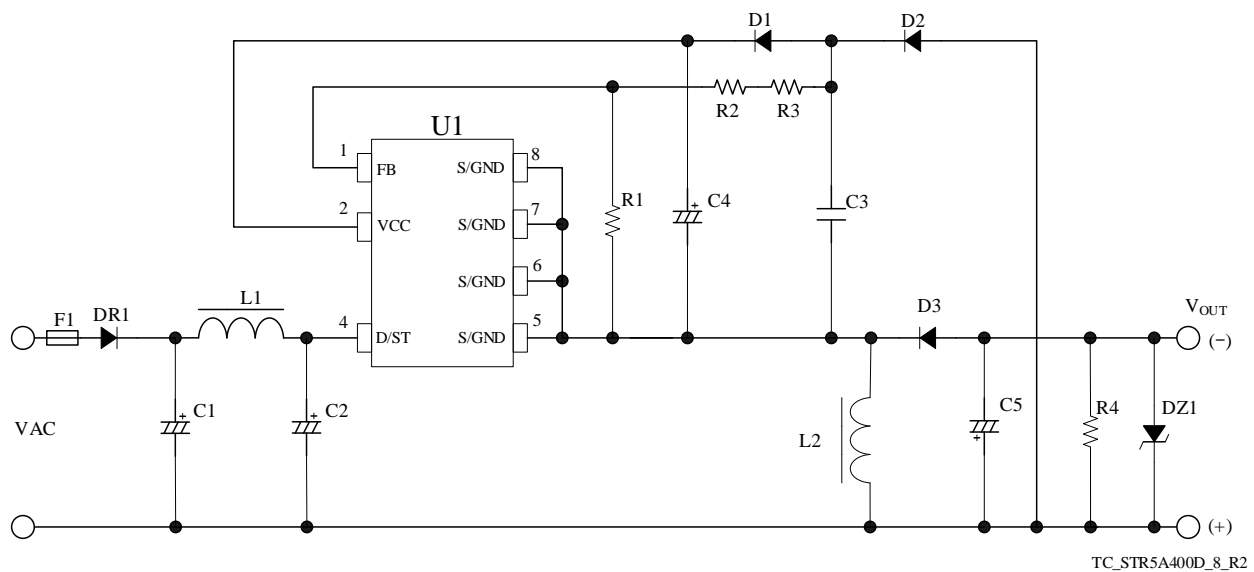

- Bill of materials

Symbol	Part type	Ratings ⁽¹⁾	Recommended Sanken Parts
DR1	General	1k V, 1 A	EM1C
F1	Fuse	250 V, 1 A	
L1 ⁽²⁾	CM inductor	330μH	
L2	Inductor	1 mH	
C1	Electrolytic	400 V, 8.2 μF	
C2	Electrolytic	400 V, 8.2 μF	
C3	Ceramic	50 V, 0.22 μF	
C4	Electrolytic	50 V, 10 μF	
C5	Electrolytic, Low impedance	25 V, 220 μF	
DZ1	Zener diode	V _Z = 18.8 V (min.)	SJPZ-E20
R1	General	10 kΩ	
R2 ⁽²⁾	General	47 kΩ	
R3 ⁽²⁾	General	4.7 kΩ	
R4 ⁽²⁾	General	6.8 kΩ, 1/4 W	
D1	Fast recovery	200 V, 1 A	SJPL-D2
D2	Fast recovery	500 V, 1 A	SJPD-D5
D3	Fast recovery	500 V, 1 A	SJPD-D5
U1	IC		STR5A464D

⁽¹⁾ Unless otherwise specified, the voltage rating of capacitor is 50 V or less and the power rating of resistor is 1/8 W or less.

⁽²⁾ It is necessary to be adjusted based on actual operation in the application.

Important Notes

- All data, illustrations, graphs, tables and any other information included in this document (the “Information”) as to Sanken’s products listed herein (the “Sanken Products”) are current as of the date this document is issued. The Information is subject to any change without notice due to improvement of the Sanken Products, etc. Please make sure to confirm with a Sanken sales representative that the contents set forth in this document reflect the latest revisions before use.
- The Sanken Products are intended for use as components of general purpose electronic equipment or apparatus (such as home appliances, office equipment, telecommunication equipment, measuring equipment, etc.). Prior to use of the Sanken Products, please put your signature, or affix your name and seal, on the specification documents of the Sanken Products and return them to Sanken. When considering use of the Sanken Products for any applications that require higher reliability (such as transportation equipment and its control systems, traffic signal control systems or equipment, disaster/crime alarm systems, various safety devices, etc.), you must contact a Sanken sales representative to discuss the suitability of such use and put your signature, or affix your name and seal, on the specification documents of the Sanken Products and return them to Sanken, prior to the use of the Sanken Products. The Sanken Products are not intended for use in any applications that require extremely high reliability such as: aerospace equipment; nuclear power control systems; and medical equipment or systems, whose failure or malfunction may result in death or serious injury to people, i.e., medical devices in Class III or a higher class as defined by relevant laws of Japan (collectively, the “Specific Applications”). Sanken assumes no liability or responsibility whatsoever for any and all damages and losses that may be suffered by you, users or any third party, resulting from the use of the Sanken Products in the Specific Applications or in manner not in compliance with the instructions set forth herein.
- In the event of using the Sanken Products by either (i) combining other products or materials or both therewith or (ii) physically, chemically or otherwise processing or treating or both the same, you must duly consider all possible risks that may result from all such uses in advance and proceed therewith at your own responsibility.
- Although Sanken is making efforts to enhance the quality and reliability of its products, it is impossible to completely avoid the occurrence of any failure or defect or both in semiconductor products at a certain rate. You must take, at your own responsibility, preventative measures including using a sufficient safety design and confirming safety of any equipment or systems in/for which the Sanken Products are used, upon due consideration of a failure occurrence rate and derating, etc., in order not to cause any human injury or death, fire accident or social harm which may result from any failure or malfunction of the Sanken Products. Please refer to the relevant specification documents and Sanken’s official website in relation to derating.
- No anti-radioactive ray design has been adopted for the Sanken Products.
- The circuit constant, operation examples, circuit examples, pattern layout examples, design examples, recommended examples, all information and evaluation results based thereon, etc., described in this document are presented for the sole purpose of reference of use of the Sanken Products.
- Sanken assumes no responsibility whatsoever for any and all damages and losses that may be suffered by you, users or any third party, or any possible infringement of any and all property rights including intellectual property rights and any other rights of you, users or any third party, resulting from the Information.
- No information in this document can be transcribed or copied or both without Sanken’s prior written consent.
- Regarding the Information, no license, express, implied or otherwise, is granted hereby under any intellectual property rights and any other rights of Sanken.
- Unless otherwise agreed in writing between Sanken and you, Sanken makes no warranty of any kind, whether express or implied, including, without limitation, any warranty (i) as to the quality or performance of the Sanken Products (such as implied warranty of merchantability, and implied warranty of fitness for a particular purpose or special environment), (ii) that any Sanken Product is delivered free of claims of third parties by way of infringement or the like, (iii) that may arise from course of performance, course of dealing or usage of trade, and (iv) as to the Information (including its accuracy, usefulness, and reliability).
- In the event of using the Sanken Products, you must use the same after carefully examining all applicable environmental laws and regulations that regulate the inclusion or use or both of any particular controlled substances, including, but not limited to, the EU RoHS Directive, so as to be in strict compliance with such applicable laws and regulations.
- You must not use the Sanken Products or the Information for the purpose of any military applications or use, including but not limited to the development of weapons of mass destruction. In the event of exporting the Sanken Products or the Information, or providing them for non-residents, you must comply with all applicable export control laws and regulations in each country including the U.S. Export Administration Regulations (EAR) and the Foreign Exchange and Foreign Trade Act of Japan, and follow the procedures required by such applicable laws and regulations.
- Sanken assumes no responsibility for any troubles, which may occur during the transportation of the Sanken Products including the falling thereof, out of Sanken’s distribution network.
- Although Sanken has prepared this document with its due care to pursue the accuracy thereof, Sanken does not warrant that it is error free and Sanken assumes no liability whatsoever for any and all damages and losses which may be suffered by you resulting from any possible errors or omissions in connection with the Information.
- Please refer to our official website in relation to general instructions and directions for using the Sanken Products, and refer to the relevant specification documents in relation to particular precautions when using the Sanken Products.
- All rights and title in and to any specific trademark or tradename belong to Sanken and such original right holder(s).

DSGN-CEZ-16003